



- INTRODUCTION
- CONTROLS, INDICATORS AND CONNECTORS
- BASIC SYSTEM CONNECTIONS AND ADJUSTMENTS
- POWER SUPPLY
- PREPARATIONS
- SETTING AND ADJUSTMENTS BEFORE SHOOTING
- SHOOTING OPERATION
- PLAYBACK MODE
- TIME CODE OPERATION
- S.S.F. (Super Scene Finder)
- USING EXTERNAL COMPONENTS
- SETUP MENU
- FEATURES OF THE CAMERA SECTION
- OTHERS

PrecautionsForUseoftheDVConnector

- Be sure to follow the procedure outlined below when connecting.
 1. Turn ON the GY-DV500 and the equipment to be connected.
 2. Set the VCR Setup Menu item No. 126 INPUT SELECT.
 3. Insert the videocassette.
 4. Connect the DV cable.

(If the procedure is performed in incorrect order, noise may appear in the recording and playback picture and the sound may fall out. If this occurs, disconnect the DV cable and then connect it again following steps 1 to 4 of the above procedure.)
- When recording the GY-DV500 playback picture using another component with DV connector, such as a non-linear editing controller, be sure to set the VCR Setup Menu item No. 126 INPUT SELECT to **IEEE1394**.
(If the INPUT SELECT item is set to CAMERA, be sure to perform steps 1 to 4 of the above procedure.)
- When making a backup recording on another component via the DV connector while recording with the GY-DV500, be sure to set the VCR Setup Menu item No. 126 INPUT SELECT to **CAMERA**.
(If the INPUT SELECT item is set to IEEE1394, be sure to perform steps 1 to 4 of the above procedure.)

SC96935-001

Precautions for Use of Head Cleaning Tape

- Adhere to the following precautions when using the head cleaning tape.
1. The tape runs for 10 seconds at a time in the PLAY mode. (The tape stops automatically and then the unit enters the SAVE MODE. However, the display back light is not turned off.) Press the PLAY button after the cleaning tape is fully loaded.
 2. Do not use the tape more than four times at the most for each cleaning.
 3. The cleaning tape can be used four times.
One time: One tape transport from the start of the rewound tape to the end of the tape.
- Use the following chart as a guide for periodical head cleaning.

Operating environment	Low temperature 0°C to 10°C	Room temperature 10°C to 35°C	High temperature 35°C to 40°C
Yardstick for use of cleaning tape	1 to 2 times every 5 hours	1 to 2 times every 20 to 30 hours	1 to 2 times every 5 hours

- Note 1) When used in a low humidity environment (10% RH to 30% RH), head cleaning should be conducted at intervals half of those given in the above chart.
- Note 2) When an ME80 tape is used immediately after head cleaning, the VTR warning (head) indicator may remain on. In this case, let the tape run as the indicator will turn off after the tape has run for a while.
- Note 3) Use the cleaning tape in the room temperature (10°C to 35°C).

SC96934-001

Precautions when writing S.S.F. data

When S.S.F. data stored in the memory of the GY-DV500 is written to the beginning of the rewound tape, approximately 5 seconds of recorded video and/or sound will be erased at the beginning.
In the case of important recordings, leave 5 seconds or more of the tape unrecorded before starting recording.

DV CAMCORDER

GY-DV500

Mini DV

INSTRUCTIONS

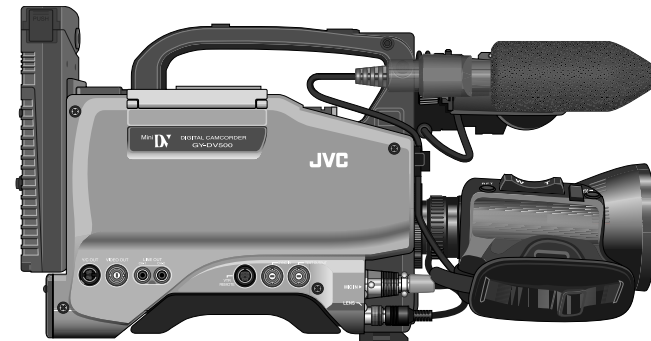

* The illustration shows the GY-DV500 DV Camcorder with the optional lens viewfinder attached.

Thank you for purchasing this JVC product. Before operating this unit, please read the instructions carefully to ensure the best possible performance.

For Customer Use :
Enter below the Serial No. which is located on the body.
Retain this information for future reference.
Model No. GY-DV500
Serial No. _____

This instructions attached to service manual is different from that which is provided the GY-DV500.

This instruction manual is made from 100% recycled paper.

SC96874 : U-ver.
SC96875 : E-ver.

IMPORTANT SAFEGUARDS

U-ver. only

1. Read all of these instructions.
2. Save these instructions for later use.
3. All warnings on the product and in the operating instructions should be adhered to.
4. Unplug this appliance system from the wall outlet before cleaning. Do not use liquid cleaners or aerosol cleaners. Use a damp cloth for cleaning.
5. Do not use attachments not recommended by the appliance manufacturer as they may cause hazards.
6. Do not use this appliance near water – for example, near a bathtub, washbowl, kitchen sink, or laundry tub, in a wet basement, or near a swimming pool, etc.
7. Do not place this appliance on an unstable cart, stand, or table. The appliance may fall, causing serious injury to a child or adult, and serious damage to the appliance. Use only with a cart or stand recommended by the manufacturer, or sold with the appliance. Wall or shelf mounting should follow the manufacturer's instructions, and should use a mounting kit approved by the manufacturer.
An appliance and cart combination should be moved with care. Quick stops, excessive force, and uneven surfaces may cause the appliance and cart combination to overturn.
8. Slots and openings in the cabinet and the back or bottom are provided for ventilation, and to insure reliable operation of the appliance and to protect it from overheating, these openings must not be blocked or covered. The openings should never be blocked by placing the appliance on a bed, sofa, rug, or other similar surface. This appliance should never be placed near or over a radiator or heat register. This appliance should not be placed in a built-in installation such as a bookcase unless proper ventilation is provided.
9. This appliance should be operated only from the type of power source indicated on the marking label. If you are not sure of the type of power supplied to your home, consult your dealer or local power company. For appliance designed to operate from battery power, refer to the operating instructions.
10. This appliance system is equipped with a 3-wire grounding type plug (a plug having a third (grounding) pin). This plug will only fit into a grounding-type power outlet. This is a safety feature. If you are unable to insert the plug into the outlet, contact your electrician to replace your obsolete outlet. Do not defeat the safety purpose of the grounding plug.
11. For added protection for this product during a lightning storm, or when it is left unattended and unused for long periods of time, unplug it from the wall outlet and disconnect the antenna or cable system. This will prevent damage to the product due to lightning and power-line surges.
12. Do not allow anything to rest on the power cord. Do not locate this appliance where the cord will be abused by persons walking on it.
13. Follow all warnings and instructions marked on the appliance.
14. Do not overload wall outlets and extension cords as this can result in fire or electric shock.
15. Never push objects of any kind into this appliance through cabinet slots as they may touch dangerous voltage points or short out parts that could result in a fire or electric shock. Never spill liquid of any kind on the appliance.
16. Do not attempt to service this appliance yourself as opening or removing covers may expose you to dangerous voltage or other hazards. Refer all servicing to qualified service personnel.
17. Unplug this appliance from the wall outlet and refer servicing to qualified service personnel under the following conditions:
 - a. When the power cord or plug is damaged or frayed.
 - b. If liquid has been spilled into the appliance.
 - c. If the appliance has been exposed to rain or water.
 - d. If the appliance does not operate normally by following the operating instructions. Adjust only those controls that are covered by the operating instructions as improper adjustment of other controls may result in damage and will often require extensive work by a qualified technician to restore the appliance to normal operation.
 - e. If the appliance has been dropped or the cabinet has been damaged.
 - f. When the appliance exhibits a distinct change in performance – this indicates a need for service.
18. When replacement parts are required, be sure the service technician has used replacement parts specified by the manufacturer that have the same characteristics as the original part. Unauthorized substitutions may result in fire, electric shock, or other hazards.
19. Upon completion of any service or repairs to this appliance, ask the service technician to perform routine safety checks to determine that the appliance is in safe operating condition.

PORTABLE CART WARNING
(symbol provided by RETAC)



SAFETY PRECAUTIONS

FOR USA AND CANADA



The lightning flash with arrowhead symbol, within an equilateral triangle is intended to alert the user to the presence of uninsulated "dangerous voltage" within the product's enclosure that may be of sufficient magnitude to constitute a risk of electric shock to persons.



The exclamation point within an equilateral triangle is intended to alert the user to the presence of important operating and maintenance (servicing) instructions in the literature accompanying the appliance.

WARNING:

TO REDUCE THE RISK OF FIRE OR ELECTRIC SHOCK, DO NOT EXPOSE THIS APPLIANCE TO RAIN OR MOISTURE.

This unit should be used with 12V DC only.

CAUTION:

To prevent electric shocks and fire hazards, do NOT use any other power source.

NOTE:

The rating plate (serial number plate) is on the top frame.

CAUTION

To prevent electric shock, do not open the cabinet. No user serviceable parts inside. Refer servicing to qualified service personnel.

AVERTISSEMENT :

POUR EVITER LES RISQUES D'INCENDIE OU D'ELECTROCUTION, NE PAS EXPOSER L'APPAREIL A L'HUMIDITE OU A LA PLUIE.

Ce magnétoscope ne doit être utilisé que sur du courant direct en 12V.

ATTENTION :

Afin d'éviter tout resque d'incendie ou d'électrocution, ne pas utiliser d'autres sources d'alimentation électrique.

REMARQUE :

La plaque d'identification (numéro de série) se trouve sur le panneau arrière de l'appareil.

WARNING ON LITHIUM BATTERY

The battery used in this device may present a fire or chemical burn hazard if mistreated. Do not recharge, disassemble, heat above 100°C (212°F) or incinerate.

Replace battery with Matsushita Electric CR2032, use of another battery may present a risk of fire or explosion.

- Dispose of used battery promptly.
- Keep away from children.
- Do not disassemble and do not dispose of in fire.

For Sweden

WARNING

Explosionsfara vid felaktigt batteribyte.

Använd samma batterityp eller en ekvivalent typ som rekommenderas av apparattillverkaren.

Kassera använt batteri enligt fabrikantens instruktion.

For Norway

ADVARSEL

Lithiumbatteri-Eksplosjonsfare.

Ved utskifting benyttes kun batteri som anbefalt av apparatfabrikant.

Brukt batteri returneres apparatleverandøren.

For Denmark

ADVARSEL!

Lithiumbatteri-Eksplosionsfare ved fejlagtig håndtering.

Udskiftning må kun ske med batteri af samme fabrikat og type.

Lever det brugte batteri tilbage til leverandøren.

For Finland

VAROITUS

Paristo voi räjähtää, jos se on virheellisesti asennettu.

Vaihda paristo ainoastaan laitevalmistajan suosittelemaan tyyppiin. Hävitä käytetty paristo valmistajan ohjeiden mukaisesti.

INFORMATION FOR USA

INFORMATION

This equipment has been tested and found to comply with the limits for a Class B digital device, pursuant to Part 15 of the FCC Rules. These limits are designed to provide reasonable protection against harmful interference in a residential installation. This equipment generates, uses, and can radiate radio frequency energy and, if not installed and used in accordance with the instructions, may cause harmful interference to radio communications. However, there is no guarantee that interference will not occur in a particular installation. If this equipment does cause harmful interference to radio or television reception, which can be determined by turning the equipment off and on, the user is encouraged to try to correct the interference by one or more of the following measures:

- Reorient or relocate the receiving antenna.
- Increase the separation between the equipment and receiver.
- Connect the equipment into an outlet on a circuit different from that to which the receiver is connected.
- Consult the dealer or an experienced radio/TV technician for help.

CAUTION

CHANGES OR MODIFICATIONS NOT APPROVED BY JVC COULD VOID USER'S AUTHORITY TO OPERATE THE EQUIPMENT.

THIS DEVICE COMPLIES WITH PART 15 OF THE FCC RULES. OPERATION IS SUBJECT TO THE FOLLOWING TWO CONDITIONS : (1) THIS DEVICE MAY NOT CAUSE HARMFUL INTERFERENCE, AND (2) THIS DEVICE MUST ACCEPT ANY INTERFERENCE RECEIVED, INCLUDING INTERFERENCE THAT MAY CAUSE UNDESIRED OPERATION

INFORMATION (FOR CANADA) RENSEIGNEMENT (POUR CANADA)

This Class B digital apparatus complies with Canadian ICES-003.

Cet appareil numérique de la Class B est conforme à la norme NMB-003 du Canada.

Thank you for purchasing the DV Camcorder GY-DV500.



This unit is a MiniDV video system format camcorder. Videocassettes which are not marked with the MiniDV symbol cannot be used with this unit.

The following phenomena may occur when tapes recorded on other units (including another GY-DV500) are recorded or played back on this camcorder.

- The transient section between scenes recorded on other units and those recorded on this unit may appear disturbed.
- Digital noise may appear during playback due to tracking errors.

MAIN FEATURES

- Compact, lightweight design
Employment of magnesium die cast has resulted in an operation-condition weight as low as approximately 5 kg including lens, viewfinder, battery, and cassette.
- DV high-quality digital format
The 4:1:1 (U-ver.), 4:2:0 (E-ver.), 8-bit, 25 Mbps component digital processing of the format ensures recording and playback with high picture quality.
- High sound quality thanks to PCM audio
Two types of sampling, 16-bit, 48 kHz sampling and 12-bit, 32 kHz sampling, ensure high-quality digital audio.
- Concentrated LCD display (back-lit)
The concentrated LCD panel shows the time code and CTL counter, tape remaining time, remaining battery power, audio levels, VCR section setup menus, hour meter data, and a variety of warning indications. The display is back-lit to facilitate viewing in dark locations.
- Time code reader/generator
The built-in time code reader/generator can be used to record SMPTE (U-ver.), EBU (E-ver.) time code and user's bits.
- AEF (Automatic Edit Function) enables neat switching between recorded scenes.
- Built-in monitor loudspeaker for audio checking
The input audio can be monitored in recording or EE mode. The playback sound can be monitored in the playback mode. The loudspeaker also outputs an alarm tone in case an abnormal condition occurs in the unit.
- Rec check function for convenient recording review
- Camera section designed with 3-CCD system for high-quality picture
Three 1/2" CCDs with 380,000 (U-ver.), 440,000 (E-ver.) effective pixels employed. Digital signal processing for reproduction of DV high-quality picture.
- Super sensitivity F/11, 2000 lux
2000 lx standard sensitivity increased to F/11 while high S/N is retained. Enables shooting at normal indoor illumination eliminating the need for extra illumination.
- LOLLUX for 0.75 lux (F1.4) illumination
Employment of LOLLUX mode ensures +33 dB gain. This is ideal for difficult shooting conditions with almost no illumination.
- Multi-Zone Auto Iris Detection Circuit
Multi-zone auto iris detection circuit ensures optimum iris position even in backlit conditions or when a bright subject moves in a frame. Switch provided for selecting over or under level.
- Safety Zone indication in viewfinder
Three types of safety zone indicator functions provided.
- Zebra pattern video level indication in viewfinder
- Full Auto Shooting (FAS) function
Eliminating the need for troublesome switch or filter operations, the FAS function automatically provides a wide range of compatibility with shooting conditions which varies as you move between indoors and outdoors or between bright and dark locations.
- Color temperature conversion filters for "3200K", "5600K", "5600 K + ND" provided.
- Variable scan shutter for U-ver.
Eliminates flicker when shooting other screen pictures than NTSC, such as computer monitor screens.
Copes with the range from 60.1 Hz to 2084.6 Hz.
- Variable scan shutter for E-ver.
Eliminates flicker when shooting other screen pictures than PAL, such as computer monitor screens.
Copes with the range from 50.1 Hz to 2067.8 Hz.
- DV (i. LINK) connector
DV connector (4-pin) provided. Enables transfer of digital data to other equipment provided with DV connector, such as a non-linear editing controller.
- S.S.F. (Super Scene Finder) function
Enables memorization of the start point and ending point of each scene or memorization of CUE points.
- 1/2" bayonet type lens
- Camera output, VCR playback output (composite/YC) possible
- External sync input connector
- Built-in color bar (SMPTE type for U-ver., EBU type for E-ver.)
- Superior operability with shutter speed and menus selected by dial.

- This unit records and plays back in the SP mode. Recording or playback in the LP mode is not possible.
- In the case of important recordings, do not record within the first 2 to 3 minutes from the beginning of the tape.
- Before recording important scenes, be sure to perform a test recording and confirm that both video and audio are recorded correctly.
- Recorded video and audio contents are for private use. Other use may infringe on the rights of copyright holders.
- JVC cannot assume liabilities that may derive from the impossibility of normal recording or playback of video or audio due to malfunction of the camcorder or the videocassette.

CONTENTS

INTRODUCTION

MAIN FEATURES	4
1. INTRODUCTION	
1-1 Main Unit Configuration	6
1-2 Precautions for Proper Use	7
1-3 Routine and Periodical Maintenance	8
1-4 Videocassette to be Used	8
1-5 Battery Pack to be Used	9
1-6 Condensation	9
1-7 Characteristic CCD Phenomena	9

2. CONTROLS, INDICATORS AND CONNECTORS

2-1 Front Section	10
2-2 Right Side Section	12
2-3 Left Side Section	18
2-4 Top Section	19
2-5 Rear Section	20
2-6 Counter Display Contents	22
2-7 Lens (optional)	23
2-8 1.5-Inch Viewfinder (optional)	24
2-9 Indications in Viewfinder	25
• Warning LED Indicators Inside the Viewfinder	25
• Viewfinder Screen Display	25

PREPARATIONS

3. BASIC SYSTEM CONNECTIONS AND ADJUSTMENTS

3-1 Basic System	30
3-2 Attaching the Zoom Lens (optional)	31
3-3 Attaching the Viewfinder	31
3-4 Attaching the Microphone (provided)	32
3-5 Attaching the Microphone (optional)	32
3-6 Attaching the Tripod Base (provided)	33
3-7 Inserting and Replacing Backup Lithium Batteries ..	34

4. POWER SUPPLY

4-1 AC Operation	35
4-2 Battery Pack Operation	35
• Attaching a Flat Shape Type Battery Pack	36
• Using an Anton-Bauer Battery Pack	37
• Remaining Battery Power Display/Precautions for the Battery Pack	38

BASIC OPERATIONS

5. PREPARATIONS

5-1 Turning the Power ON	39
5-2 Cassette Loading and Unloading	40
5-3 Setting the Date and Time	41

6. SETTING AND ADJUSTMENTS BEFORE SHOOTING

6-1 Camera Settings	42
6-2 Viewfinder Adjustment	43
6-3 External Monitor Adjustment	43
6-4 Back Focus Adjustment	44
6-5 White Balance Adjustment	45
• White Balance Adjustment	45
• Full-Time Auto White Balance (FAW)	45
6-6 Switch Settings of the VCR Section	46
6-7 Audio Input Signal Selection	47
6-8 Recording Level Adjustment	48
6-9 Monitoring Audio during Recording	49

7. SHOOTING OPERATION

7-1 Basic Recording Operation	50
7-2 VCR Save Mode	52
7-3 If Unit is Left in Record-Pause (Standby) Mode	52
7-4 Checking Recorded Contents in Record-Pause Mode (Recording Check Function)	53

8. PLAYBACK MODE

8-1 Playback Procedure	54
8-2 Fast-Forward, Rewind	55
8-3 Search	55

APPLICATION

9. TIME CODE OPERATION

9-1 Displaying Time Code	56
9-2 Presetting and Recording of Time Code	56
• Time Code Presetting Procedure	57
• Presetting User's Bit Data	57
9-3 Recording Time Codes in Continuation of Time Codes Recorded on Tape	58
9-4 Reproducing Time Codes	59

10. S.S.F. (Super Scene Finder) FUNCTION

10-1 Explanation of the S.S.F. Function	60
10-2 How to Use the S.S.F. Function	61
10-3 Deleting S.S.F. Data	62
10-4 Resetting S.S.F. Data	62
10-5 Writing S.S.F. Data to Tape	63
10-6 Outputting S.S.F. Data	63

1. INTRODUCTION

1-1 Main Unit Configuration

The GY-DV500 configuration is as shown below.

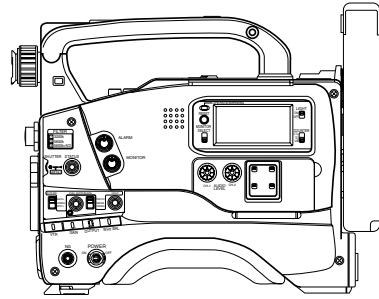

Camcorder (GY-DV500)

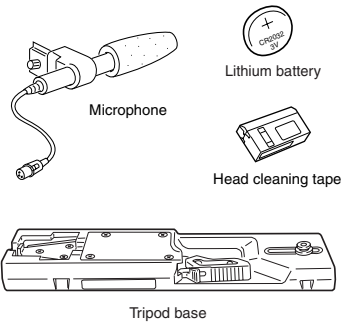

Tripod base

CAUTION :

- The front base mount may be locked while the pin of the tripod base is not inserted into the hole on the rear base mount of the unit. Therefore, after mounting, make sure that these parts are engaged properly.
- When moving the GY-DV500 mounted on a tripod, any impact or vibration should be avoided as this may cause the unit to become detached and to drop from the tripod. Be sure to remove the unit from the tripod before transporting it.

11. USING EXTERNAL COMPONENTS

- 11-1 Connecting a Video Component with DV Connector 64
- 11-2 Connecting a PC 65

12. SETUP MENU

- 12-1 VCR Setup Menu 66
 - VCR Setup Menu Configuration 66
 - Displaying and Setting VCR Setup Menus 67
 - VCR Setup Menu Contents 68
- 12-2 Camera Menu Screen Flow 70
- 12-3 How to Select from the Camera Menu 71
- 12-4 VF Display Screen 72
- 12-5 OPERATION Screen 73
- 12-6 PROCESS Screen 74
- 12-7 ADVANCED PROCESS Screen 75
- 12-8 SKIN COLOR ADJUST Screen 75
- 12-9 FILE MANAGE Screen 76
- 12-10 SETUP Screen 77
- 12-11 Resetting of Camera Menu Setting Values 78

13. FEATURES OF THE CAMERA SECTION

- 13-1 Full-Time Auto White Balance (FAW) 79
- 13-2 IRIS (Brightness) Adjustment 80
 - Adjustment of Lens Iris 80
 - Zebra Pattern Display during Manual Adjustment 80
- 13-3 Shooting the Screen Image on a Computer Monitor 81
- 13-4 Gain (Sensitivity) Adjustment 82
 - Gain Switching 82
 - Gain Boost under LOLUX Condition 82
- 13-5 Switch Setup According to Illumination and Subject 83
 - Switch Functions 83
 - Full Auto Shooting (FAS) Function 83
- 13-6 How to Use Skin Detail 84

OTHERS

14. OTHERS

- 14-1 Troubleshooting 86
 - Alarm Indications 86
 - Warnings in Viewfinder 88
 - Troubles with Error Code Outputs 90
 - Troubles without Error Code Outputs 91
- 14-2 Hour Meter Display 92
- 14-3 Specifications 93
 - Optional Accessories 94
 - External Dimensions 94

1. INTRODUCTION

1-2 Precautions for Proper Use

- **Supply voltage**
Make sure that the power is between 11 V and 15 V DC. If the power voltage is too low, abnormal color and increased noise may occur. Do not exceed 15 V DC in any case, or the unit could be damaged.
- **Allowable ambient temperature and humidity**
Be sure to use the unit within the allowable temperature range of 0°C to 40°C and a relative humidity of 30% to 80%. Using the unit at a temperature or humidity outside the allowable ranges could result not only in malfunction but the impact on the CCD elements could be serious as small white spots may be generated. When storing the GY-DV500 for a long time, the storage temperatures should be -20°C to 60°C.
- **Strong electromagnetic waves or magnetism**
Where there are strong electromagnetic waves or magnetism, for example near a radio or TV transmitter, transformer, motor, etc., the picture may contain noise and the colors may be incorrect.
- **Use of wireless microphone near the camera**
When a wireless microphone or wireless microphone tuner is used near the camera during recording, the tuner could pick up noise.
- **Avoid using or placing the unit in places;**
 - subject to extreme heat or cold;
 - with excessive dirt or dust;
 - with high humidity or moisture;
 - subject to smoke or vapour such as near a cooking stove;
 - subject to strong vibrations or on an unstable surface.
 - also do not leave the unit for long hours in a parked car under direct sunlight or near room heating equipment.
- **Protect the unit from being splashed with water (especially when shooting in the rain).**
- **Protect the unit from being wet when shooting on a beach.** In addition, salt and sand may adhere to the camera body. Be sure to clean the camera after use.
- **Protect the unit against penetration of dust when using it in a place subject to sandy dust.**
- **Optical performance of lens**
Due to the optical performance of the lens, color divergence phenomena (magnification chromatic aberration) may occur at the periphery of the image. This is not a camera malfunction.
- **Noise may appear in the viewfinder when switching between the playback picture and the EE picture.**
- **Setup level (NTSC only)**
The video signal of the unit's video output is provided with a setup level when shipped from the factory. If you want to turn OFF the setup level, please consult the person in charge of professional video equipment at your nearest JVC-authorized service agent. The setup level is never attached to the video signal recorded on the tape.
- **Use the unit in an upright position.**
If placed on its side, heat release efficiency will deteriorate, adversely affecting the tape transport. Depending on circumstances the tape may also be damaged.
- **Vibrations**
Colors may fail to appear during VCR playback in locations subjected to vibrations.
- **Precautions for transportation**
Do not drop or hit the unit against a hard object.
- **Remove the videocassette before transporting the unit.**
- **Do not insert an object other than a videocassette in the cassette insertion slot.** Be sure to close the cassette cover when the unit is not to be used for a long period
- **Do not set the POWER switch to OFF or remove the power cable during recording or playback.** Otherwise the tape may be damaged.
- **When the unit is not in use, be sure to set the POWER switch to OFF in order to reduce power consumption.**
- **Cleaning the body:** Wipe body with a dry, soft cloth. When it is extremely dirty, soak the cloth in a solution of neutral detergent, wring it out and then wipe. To prevent deformation of the body, etc. and to avoid operation hazards, do not allow volatile liquids such as benzine and thinner to touch the body, and do not wipe it with a cloth soaked in such a liquid.
- **The camera may be unstable in the period immediately after the power is turned on, but this is not a malfunction.**
- **If a tape containing recorded PAL signals is played back, the GY-DV500 automatically enters the STOP mode.** If this happens, remove the videocassette so that the unit returns to its normal state. (U-ver.)
- **If a tape containing recorded NTSC signals is played back, the GY-DV500 automatically enters the STOP mode.** If this happens, remove the videocassette so that the unit returns to its normal state. (E-ver.)

CAUTION :

- Do not point the lens or viewfinder directly at the sun or other strong light source.
 - Eye damage could result.
 - If the lens or viewfinder is left pointed at the sun, rays may collect inside the unit and cause damage or a fire.
- When carrying the camera, be sure to hold the carrying handle. Holding the lens or viewfinder may result in damage.

1. INTRODUCTION

1-3 Routine and Periodical Maintenance

The GY-DV500 incorporates precision mechanical parts, which will collect dirt, wear out and deteriorate as the unit is used. On the other hand, when the unit has been used for a long period in a normal environment, the heads, drums and tape transport mechanisms also collect dirt deposited on them. Furthermore, dust which penetrates the inside of the VCR section especially during outdoor use will promote the wear and deterioration of mechanical parts by causing poor contact between tape and heads or failing to maintain the video and audio quality at high levels. To prevent wear and deterioration, clean the mechanical parts using a head cleaning tape as routine maintenance. However, cleaning with a head cleaning tape alone is not enough for cleaning the entire tape transport mechanism, it is also recommended to apply periodical maintenance (inspection) to prevent troubles that may be caused by the sudden occurrence of failure. As the replacement, adjustment and servicing of parts require advanced skill and equipment, please consult the person in charge of professional video equipment at your nearest JVC-authorized service agent.

Head Cleaning

- To maintain beautiful pictures and sound, be sure to use a head cleaning tape to clean the head periodically. (Read the separate sheet "Precautions for Use of Head Cleaning Tape".) If head cleaning is not performed periodically, a type of mosaic noise called block noise may appear in the picture or sound may be interrupted.



Block Noise

- Use the provided head cleaning tape. Do not use head cleaning tapes other than specified. For instructions on how to use the head cleaning tape and precautions for its use, read the separate sheet "Precautions for Use of Head Cleaning Tape".
- When dirt adheres to the heads of the GY-DV500, the following indications appear during playback and recording check using the RET button on the lens section.
 - "RF" appears on the display panel.
 - "HEAD CLOG" appears on the counter display.
 - "VTR WARNING (HEAD)" appears in the viewfinder.
- If this kind of indication appears, please stop the recording. Head cleaning is required. This indicator disappears when the POWER is turned OFF, or when the cleaning tape is played back.

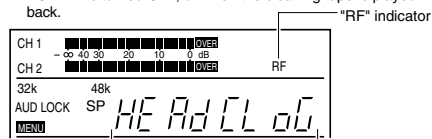

"HEAD CLOG" indicator

1-4 Videocassette to be Used

- Use JVC's videocassette tapes marked with MiniDV for this unit.
- Videocassettes cannot be used upside down.
- Avoid storing a videocassette with unevenly wound tape, as this may damage the tape. Rewind it to the beginning before placing a cassette into storage.
- Store videocassettes in a place with little humidity and good ventilation where mould does not form.
- After a videocassette tape has been used repeatedly, it becomes unable to maintain full performance due to an increase in noise caused by dropouts, etc. Do not continue to use a dirty or damaged tape, as this will reduce the rotary head life.
- Note that if an ME80 videocassette is used at low temperatures, block noise tends to occur due to head contamination.

Periodical Maintenance

Contents : Check or replace the following mechanical parts according to the running time.

Running Time	500H	1000 H	1500H	2000H
Drum ass'y (including heads)	○	○	○	●
Head cleaner	☆	●	☆	●
Tape guides & rollers	○	☆	☆	●
Rotary encoder	-	☆	-	●
Belts & gears	☆	●	☆	●
Drive parts	○	○	☆	●

- : Clean, check and adjust.
- ☆: Clean and check. Replace as required.
- : Replace.

The maintenance contents vary depending on the operating environment and method. Therefore, the above data should be considered as a reference.

Time management

The accumulated running time of the unit can be confirmed with the hour meter display (which shows the accumulated drum running time). For details, see "HOUR METER DISPLAY" on page 92.

For consultations related to the maintenance programming or cost, please contact the person in charge of professional video equipment at your nearest JVC-authorized service agent.

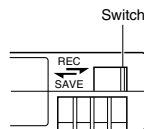

- Videocassette tapes marked MiniDV are provided with a switch on the back for use in preventing accidental erasure.
- Slide the switch to SAVE to protect the required recording in the tape from being overwritten.
- To record on the tape, slide the switch to REC.

1. INTRODUCTION

1-5 Battery Pack to be Used

The GY-DV500 can use any of the following battery packs.

- Flat shape type
- Anton-Bauer battery pack: Trimpack 13/14 Series
Magnum 13/14 Series
Compack 13/14 Series
Propack 13/14 Series

* An Anton-Bauer battery pack cannot be connected directly to the camera. It is necessary to mount the optional battery holder.

- Battery holder: Anton-Bauer QRQ27
For details on how to mount the battery holder, see page 37.

To display the remaining battery power accurately, set the VCR Setup Menu item No. 396 BATTERY TYPE according to the type of the battery pack in use. (See page 69)

1-6 Condensation

- If the unit has been cooled down in a cold place and is then carried to a warm place, the moisture contained in the warm air may adhere to the head drum or tape guides and be cooled into water droplets. This phenomenon is referred to as condensation (dewing). When this occurs, the head drum and tape guides are covered with droplets allowing the tape to be stuck to them, leading to tape damage.
- Condensation occurs in the following cases:
 - When the unit is suddenly moved from a cold place to a warm place.
 - When a room heater has just started or when the unit is exposed directly to cold air from an air conditioner.
 - When the unit is placed in a very humid place.

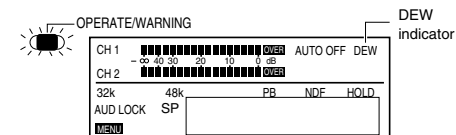
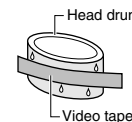

Do not leave the videocassette inserted when moving the camera under conditions where the temperature environment changes.

1-7 Characteristic CCD Phenomena

Smear and Blooming

Due to the physical structure of a CCD it is possible to induce vertical streaking (called "smear") when shooting an extremely bright light source. Another effect is the expansion of light around a bright light or object (called "blooming"). The CCD employed in this unit is characterized by inducing very little smear or blooming. Nevertheless, please be careful when shooting a bright light source.

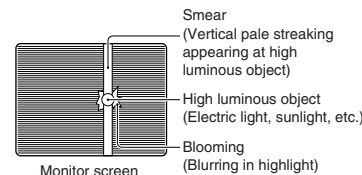

Moire or Aliasing

Shooting stripes or fine patterns may cause a jagged effect or a banding in fine mesh patterns.

White dots

High temperatures can cause CCD sensor pixels to malfunction with the effect of white dots in the image. This condition is conspicuous especially when gain is applied. This is a characteristic of the charged-coupled device (CCD). As far as possible, use the unit under conditions where the temperature of the unit does not increase.

For servicing
See the service manual page 2-7 "2.4.3 Cleaning".
For the part No. of cleaning tape, see section "7.1 PACKING" on this service manual.

2. CONTROLS, INDICATORS AND CONNECTORS

2. CONTROLS, INDICATORS AND CONNECTORS

2-1 Front Section

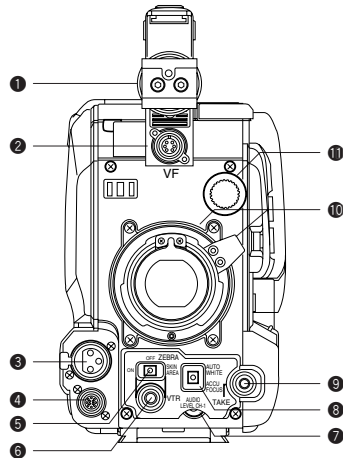

1 Viewfinder mount base, sliding securing ring

Mount the viewfinder on the base and secure it using the sliding securing ring.

☞ See "Attaching the Viewfinder" on page 31.

2 [VF] Viewfinder connector (6-pin)

Connect the cable from the viewfinder here.

3 [MIC IN] Microphone input connector (XLR 3-pin)

Balanced 3-pin connector for camera microphone.

- When the camera microphone to be connected is a phantom microphone or other type of microphone, set the CAM MIC 48V item on the Camera Setup menu. See page 77.
- When using a microphone with this connector, set the AUDIO INPUT switches 7 8 on page 14 to FRONT in accordance with the audio channel (CH1 or CH2) to be recorded.

☞ See page 14.

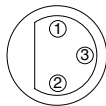

Pin No.	Function
1	GND
2	HOT
3	COLD

CAUTION:

- The provided microphone is a phantom microphone. Please confirm that the CAM MIC 48 V item on the Camera SETUP Menu is set to "ON".
- When using a microphone other than a phantom microphone, first set the CAM MIC 48 V item to "OFF" before connecting the microphone. Otherwise the microphone may be damaged.

4 [LENS] Lens control connector

Connect 12-pin lens control cable from lens.

Pin No.	Function	Pin No.	Function
1	RET switch	7	IRIS position
2	VCR trigger	8	IRIS A/R INPUT
3	GND	9	EXTENDER position
4	Lens AUTO/MANU control	10	ZOOM position
5	IRIS control	11	—
6	+12V DC	12	—

5 [ZEBRA] Switch

When this switch is ON, a zebra pattern is superimposed on the viewfinder areas having video levels with a luminance level of 70% to 80%. This pattern can be used as a reference for manual adjustment of the lens iris.

* The zebra patterns are only displayed on the viewfinder screen. The zebra patterns are not generated for the MONITOR OUT or Y/C OUT output.

☞ See "Zebra Pattern during Manual Adjustment" on page 80.

- The default value is 70% - 80%. The luminance level can be changed with the ZEBRA setting in the VF DISPLAY Menu screen.

☞ See "ZEBRA" item on page 72.

While this switch is pressed to the SKIN AREA side, the color tone areas specified with the SKIN DTL ADJUST item on the ADVANCED PROCESS MENU are indicated in the viewfinder. The switch returns to the OFF position when released.

☞ See "How to Use Skin Detail" on page 84.

- The Skin Detail color tone areas are not indicated while the VTR playback picture is shown in the viewfinder.

6 [VTR] VTR trigger button (record start/stop button)

Record start/stop can be effected with this button.

(It is interlocked with the VTR trigger button on the lens section.)

7 [AUDIO LEVEL CH-1] CH-1 recording level control

Adjusts the recording level of the CH1 audio signal input. Normally, the camera is used with the control set to the maximum (10) position.

- To use this control, set the VCR Setup Menu item No. 246 FRONT VOLUME ENABLE to "ENABLE".

Note:

Even when the VCR Setup Menu item No. 246 is set to DISABLE, the recording level changes slightly when this control is turned.

8 [AUTOWHITE./ACCU FOCUS] switch

AUTO WHITE:

- First, position a white object to occupy 80% of the centre of the image.
- Setting this switch to the upper position ("AUTO WHT") will provide automatic adjustment for white balance.

* It is not activated in preset, full auto shooting, full-time auto white balance and color bar modes.

☞ See "White Balance Adjustment" on page 45.

2-1 Front Section (Cont'd)

ACCU-FOCUS:

- When this switch is set to "ACCU FOCUS" in the lower position, the lens iris will be forced to open for approximately ten seconds.
- The depth of field can be reduced and the lens focusing can be adjusted more accurately.

CAUTION:

- As the automatic shutter is activated here, flicker may appear on the screen depending on the lighting conditions (such as a fluorescent lamp, etc.)
- This operation is not possible in the LOLUX mode.

9 [TAKE] button

The Super Scene Finder (S.S.F.) function retains the time code data for IN point and OUT point or CUE point in the unit's memory.

☞ See "S.S.F. Function on" page 60.

10 Lens mounting ring/Lens lock lever

Hold the lens and use the lever to turn the ring anticlockwise to release lens.

To mount lens make sure the lens guide pin fits well, and then turn the ring clockwise until firm.

☞ See "Attaching the Zoom Lens" on page 31.

11 [FILTER] Color temperature conversion filter control knob

This knob changes the internal color temperature filter.

☞ See "Camera Settings" on page 42.

2. CONTROLS, INDICATORS AND CONNECTORS

2. CONTROLS, INDICATORS AND CONNECTORS

2-2 Right Side Section

2-2 Right Side Section [Camera Setting Section]

[Camera Setting Section]

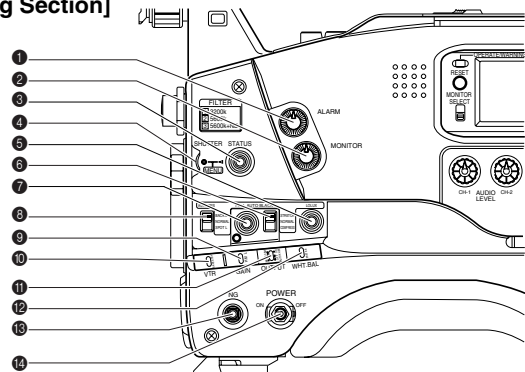

1 [ALARM] Volume control

Turn to adjust the volume of the alarm tone that is output from the monitoring loudspeaker or earphone in case of a warning or other abnormal condition occurring with the GY-DV500.

Turn this control anticlockwise to reduce the volume. Setting this control to the minimum position mutes the alarm tone.

2 [MONITOR] Audio monitor volume control

Adjusts the volume of the monitoring loudspeaker and earphone. The audio is muted when this control is set to the minimum position.

3 [STATUS] Status/menu button

Pressing this button in the normal screen mode (condition when menu is not shown) displays a status screen in the viewfinder. The displayed status mode changes each time the button is pressed.

☞ See "Status Screens" on page 25.

Pressing this button for more than 1 second in the normal screen mode displays the Camera Menu screen in the viewfinder. Pressing this button while the menu screen is displayed in the viewfinder makes the menu screen disappear.

☞ See "How to Select from the Camera Menu" on page 71.

4 [SHUTTER/MENU] dial

- Pressing this dial once in the normal screen mode (condition when menu is not shown) displays the shutter speed for approximately 5 seconds. When this dial is turned upwards while the shutter speed is displayed, the shutter speed becomes slower. When turned downwards, the shutter speed becomes faster. The selected shutter speed is memorised for each file. To return the memorised shutter speed to the factory preset, press the dial one more time while the shutter speed is displayed.

- When this dial is turned upwards or downwards while the menu screen is displayed, the cursor (>) also moves upwards or downwards to allow selection of items in the menu. To change the setting value of the item, press this dial. When the setting value starts blinking, turn this dial upwards or downwards to change the setting.

☞ See "How to Select Camera Menus" on page 71.

5 [LOLUX] LOLUX On/Off button

This button toggles the LOLUX mode on and off.

- LOLUX gain gives extremely low light level sensitivity for special applications. This will result in an increase of 33 dB (approximately 45 times) in the LOLUX mode.
- LOLUX operation takes priority over normal gain setting.
- If the unit is placed in the LOLUX mode when it is in full auto shooting mode, the auto level control (ALC) (one of the full auto shooting functions) will be made inactive, so that the LOLUX mode is given preference (FAW still remains active).

☞ See "GAIN BOOST UNDER LOLUX CONDITION" on page 82.

6 [BLACK] Black stretch/black compression switch

Switches the gain for the dark section of the image. Set to an appropriate position depending on the video signal to be shot.

STRETCH : By stretching the signal only for the dark section, contrast in the dark portion of the image is enhanced.

NORMAL : Standard mode.

COMPRESS : When an entire image is relatively light and the contrast is low, the gain of the dark section is compressed to increase the contrast.

7 [FULL AUTO] Full auto shooting ON/OFF button and indicator

- This switch toggles the full auto shooting function on and off.
- The indicator lights when in the full auto mode.
- Full auto shooting combines the auto iris, auto level control (ALC) to automatically adjust the video signal level and the white balance to their optimum levels.
- The iris is placed in automatic mode even if the iris mode switch of the lens is in manual.
- The gain will vary continuously to the maximum of +12 dB. The shutter speed will vary continuously to the minimum of 1/240 of a second.

☞ See "Full Auto Shooting (FAS) function" on page 83.

8 [AUTO IRIS] Auto iris level switch

This switch selects the automatic iris adjustment reference value according to the condition in which the camera is used.

BACK. L : Under back light (Opens the iris about 1 step from the standard level.)

NORMAL : Normal condition

SPOT. L : Under spotlight (Closes the iris about 1 step from the standard level.)

☞ See "SWITCH FUNCTIONS" on page 83.

9 [GAIN] switch

Electronically boosts the light sensitivity when there is insufficient illumination on the subject. The boosting level differs depending on the switch position as follows: (Factory presets)

L : 0 dB (no boosting is applied)

M : 9 dB (boosted to approximately 3 times the original)

H : 18 dB (boosted to approximately 8 times the original)

- The boosting level for each switch position can be changed with the OPERATION menu screen. (☞ See page 73.)

The more the boosting level is increased, the more the resulting image will be noisy.

10 [VTR SAVE/STBY] switch

Used to select the status of the GY-DV500 when the power is turned ON and a videocassette is loaded.

STBY: The GY-DV500 is in the standby mode.

When a recordable videocassette is loaded, the GY-DV500 enters the record-pause mode.

SAVE: The GY-DV500 is in the save mode.

- The status of the GY-DV500 is displayed on the Status screen 1 in the viewfinder.

11 [OUTPUT] Color bar/Camera/Auto knee switch

This switch is used to select the output signal. When the video signal from the shooting camera is selected, the auto knee function is available.

CAM. AUTO KNEE ON:

Outputs the video signal from the shooting camera. In this mode, the auto knee function is available.

CAM. AUTO KNEE OFF:

Outputs the video signal from the shooting camera. In this mode, the auto knee function is not available.

BARS: Outputs the color bar signal. In this mode, the auto knee function is not available. Set to this position when adjusting the video monitor or when recording the color bar signal.

AUTO KNEE function

When shooting a foreground subject, such as a human being, etc., with a high-brightness background, if the brightness level is set for the foreground subject, the background image will be blurred with white. In such a case, a clearer background is obtained when the auto knee function is used.

It is effective especially in the following cases:

- When shooting a human being indoors with a view to the landscape out through a window.
- When shooting a human being in the shade on a fine day.
- When shooting a high-contrast scene.

CAUTION:

If a fast moving high-brightness section like a car in sunlight is shot, the auto knee function may change the brightness of the entire image along with the motion of the object. In this case, set the auto knee function to OFF.

12 [WHT.BAL] White balance switch

Three white balance modes are selectable with this switch.

B : If white balance is performed with the switch in this position, it will be memorised into B.

A : If white balance is performed with the switch in this position, it will be memorised into A.

PRST (PRESET) : A non-erasable white balance setting at 3200K.

- FAW (Full-time Auto White) mode can be set to A, B or PRESET with the OPERATION MENU (see page 73). In the FAW mode, video color temperatures are constantly sampled for automatic adjustment to a proper white balance.

13 [NG] button

Pressing this button while recording or in the record-pause mode deletes the S.S.F. data stored in the memory of the GY-DV500 with the S.S.F. (Super Scene Finder) function. This function is only valid in the MARK mode.

☞ See "S.S.F. (Super Scene Finder) Function" on page 60.

14 [POWER] switch

Turn the power ON and OFF with this switch.

When this switch set to ON while a videocassette is loaded, the GY-DV500 status differs depending on the setting of the VTR (SAVE/STBY) switch ⑩.

For servicing

Even during FAS operation, the priority setting for the audio recording level is "CH1/CH2 AUDIO SELECT".

For servicing
When replacing the Lithium Battery, see page 41 "Setting the Date and Time" and then set the date and time as described therein.

2. CONTROLS, INDICATORS AND CONNECTORS

2-2 Right Side Section (Cont'd)

[Audio Setting Section]

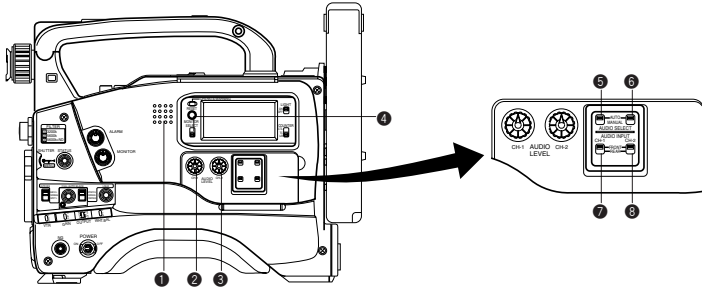

1 [MONITOR LOUDSPEAKER]

- Enables EE monitoring of the input audio signal during recording, in the record-pause mode or in the stop mode. Outputs the playback sound in the playback mode. The sound to be output can be selected using the MONITOR SELECT switch 4.
 - The loudspeaker volume can be adjusted with the MONITOR volume control 2 on page 12. The audio from the loudspeaker is not output when an earphone is plugged into the EARPHONE jack 3 on page 20. The warning alarm tones are also output through this loudspeaker.
- See "ALARM INDICATIONS" on pages 86.

2 [CH1 AUDIO LEVEL] CH1 recording level control

- Adjust the recording level of the CH1 audio channel with this control.
- To use this control, set the CH1 AUDIO SELECT switch 5 to "MANUAL". This control works regardless of the setting of the VCR Setup Menu item No. 246 FRONT VOLUME ENABLE. To use this control, set the AUDIO LEVEL CH-1 recording level control (7 on page 10) on the front section to the maximum (10) position, or set the VCR Setup Menu item No. 246 FRONT VOLUME ENABLE to "DISABLE".

3 [CH2 AUDIO LEVEL] CH2 recording level control

- Adjust the recording level of the CH2 audio channel with this control.
- This control is valid only when the CH2 AUDIO SELECT switch 6 is set to "MANUAL".

4 [MONITOR SELECT] audio monitor selector switch

- This switch is used to select the monitor sound output from the MONITORING LOUDSPEAKER 1 or via the EARPHONE jack 3 on page 20.
- CH-1** : The CH1 channel audio is output.
MIX : CH1 and CH2 channel audio are output mixed.
CH-2 : The CH2 channel audio is output.

CAUTION:

Make sure to move switches all the way. Do not leave a switch stopped in a midway position. Noise will be generated and operation irregularities will occur.

5 [CH-1 AUDIO SELECT] selector switch

- This switch is used to select the method for adjusting the recording level of the CH-1 audio channel.
- AUTO** : The recording level is held at the reference level even when sounds greater than the reference level are input. The recording level does not increase when the input level is low.
- MANUAL**: The recording level can be adjusted with the CH-1 AUDIO LEVEL control 2 or the CH-1 AUDIO LEVEL control 7 on page 10. To use the AUDIO LEVEL CH-1 recording level control on the front section, set the VCR Setup Menu item No. 246 FRONT VOLUME ENABLE to "ENABLE".

6 [CH-2 AUDIO SELECT] selector switch

- This switch is used to select the method for adjusting the recording level of the CH-2 audio channel.
- AUTO** : The recording level is held at the reference level even when sounds greater than the reference level are input. The recording level does not increase when the input level is low.
- MANUAL**: The recording level can be adjusted with the CH-2 AUDIO LEVEL control 3.

7 [CH-1 AUDIO INPUT] selector switch

- This switch is used to select the input section of the CH1 audio channel.
- FRONT** : The sound from the MIC IN connector on the front side section is input.
REAR : The sound from the CH-1 AUDIO IN connector on the rear side section is input.

8 [CH-2 AUDIO INPUT] selector switch

- This switch is used to select the input section of the CH2 audio channel.
- FRONT** : The sound from the MIC IN connector on the front side section is input.
REAR : The sound from the CH-2 AUDIO IN connector on the rear side section is input.

2. CONTROLS, INDICATORS AND CONNECTORS

2-2 Right Side Section (Cont'd)

[VCR Setup Block]

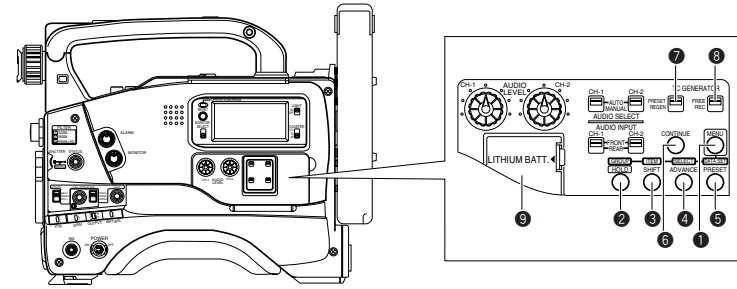

1 [MENU] button

- Press this button to enter the VCR setup menu mode. When the VCR setup menu mode is engaged, the "MENU" indicator in the LCD display lights and the counter display and viewfinder display are changed to the menu indication. In the VCR setup menu mode, pressing this button resumes the normal mode.

2 [HOLD/GROUP] button

- Press this button when presetting the time code or user's bit. The presently displayed data is held (the "HOLD" indicator lights on the display) and the leftmost digit of the counter blinks. Pressing this button during presetting of time code or user's bit cancels the operation and recalls the previous display contents.
- In setup menu mode, this button is used to select the menu group.

3 [SHIFT/ITEM] button

- During presetting of time code or user's bit, press this button to select the digit to be set. Each press of the button shifts the digit to be set (which blinks) to the right.
- In setup menu mode, this button is used to select the menu item.

4 [ADVANCE/SELECT] button

- During presetting of time code or user's bit, press to select the value of the digit to be set. Each press of the button increases the number by 1.
- In setup menu mode, this button is used to select the value of a menu item.

5 [PRESET/DATA SET] button

- During presetting of time code or user's bit, press to save the set value in the preset memory. The set time code or user's bit will be preset in the time code generator.
- In setup menu mode, this button is used to confirm the menu item setting and save the data in the memory.

- For details of the presetting of time code or user's bit, see page 56.
- For details on the setup menus, see page 67.

6 [CONTINUE] button

- If this button is pressed simultaneously with the LOG button 9 on page 19 during the stop mode, the tape winds to the last S.S.F. data OUT point.
- See "About the Scene End Cue Up Function" on page 63.

TIME CODE GENERATOR setting switches

7 [PRESET/REGEN] switch

- Toggles the time code generator mode between PRESET and REGEN.
- PRESET**: Preset mode. Set to this position when newly presetting and recording the time code.

- REGEN** : Regeneration mode, in which the unit reads existing time codes on the tape and records time codes in continuation of the existing ones. Set to this position when you want to add additional time codes to time codes already recorded on the tape.

8 [REC/FREE] run switch

- Selects the time code running mode while the time code generator is in preset mode. This switch is not effective in the REGEN mode.

- REC** : The time code runs only during recording. This position allows you to record continuous time codes when recording scenes one after another.

- FREE** : The time code runs permanently.
 * If this position is used when recording scenes one after another, the time codes become discontinuous at the change points between scenes.

9 Lithium Battery Installation Compartment

- Install a lithium battery (CR2032) in this compartment. The battery is used for the backup of the time code. The GY-DV500 is delivered without the battery installed. The provided lithium battery is for test use. It is recommended to install a new lithium battery. A new lithium battery can power the backup for about one year. See "Inserting and Replacing Backup Lithium Batteries" on page 34.

2. CONTROLS, INDICATORS AND CONNECTORS

2-2 Right Side Section (Cont'd)

[VCR Display Section]

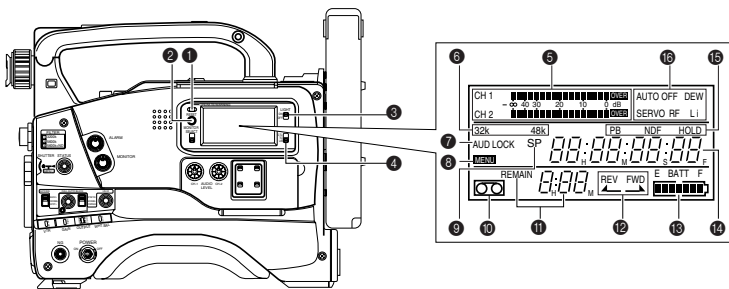

1 [OPERATE/WARNING] indicator

Normally lights green.
Lights orange during the VTR SAVE (tape protect) mode.
This indicator lights or blinks in red in the case of a warning condition related to the remaining tape time, remaining battery power or other abnormal condition in the unit.
For details, see "ALARM INDICATIONS" on pages 86.

2 [RESET] button

- Press to reset the CTL counter value.
- Pressing the button during presetting of time code or user's bit resets the time code or user's bit data to "00:00:00:00".

3 [LIGHT] switch

Turns the illumination of the back-lit display ON or OFF.
ON : The display is illuminated.
OFF : The display is not illuminated.
(Keep this switch at OFF during battery operation of the GY-DV500 or when it is required to reduce the power consumption for some reason.)

Note:

When a videocassette is loaded and the VTR switch is set to SAVE mode, the illumination will go out even if the backlight is ON.

4 [COUNTER] switch

Selects the contents displayed on the LCD counter display. The displayed contents when TC or UB is set can be selected using the VCR Setup Menu item No. 516 DISPLAY SELECT.

- CTL** : Set to this position to display the CTL counter.
TC : Set to this position to display time codes or for presetting the time code. (When the Menu item No. 516 DISPLAY SELECT is set to "TC".)
Time (Hour, Min., Sec.) is displayed. (When the Menu item No. 516 DISPLAY SELECT is set to "CLOCK".)
UB : Set to this position to display the user's bits of time codes or presetting the user's bit. (When the Menu item No. 516 DISPLAY SELECT is set to "TC".)
Date (Month, Day, Year) is displayed. (When the Menu item No. 516 DISPLAY SELECT is set to "CLOCK".)

☞ See "VCR Setup Menu Contents" on page 69.

5 Audio level meters

Show the audio input level of the CH-1 and CH-2 channels in the record mode or EE mode.
In the playback mode, the meters show the playback audio level.

"OVER" lights in case of excessive input.

CAUTION:

Immediately after the power is switched ON, the level meters may fluctuate. This is not a malfunction.

6 32K/48K sampling frequency indication

Indicates whether audio recording or playback occurs with 12-bit, 32 kHz sampling or 16-bit 48 kHz sampling.

- In the recording mode, the sampling frequency is set using the VCR Setup Menu item No. 245 SAMPLING RATE.
- In the playback mode, the indication conforms to the sampling rate of the recorded sound.

7 [AUD LOCK] indicator

Indicates whether the audio signal is locked to the video signal during recording and playback.

8 [MENU] indicator

Appears when the MENU button ① on page 15 is pressed to select the VCR Setup Menu.

9 SP indicator

Indicates the tape speed in record mode.

10 Cassette indicator

Lights when the unit is loaded with a videocassette. Blinks during ejection or tape loading.

11 [REMAIN] indicator

The remaining tape time (minutes and seconds) is shown. For details, see page "Remaining Tape Time Display" on page 22.

2. CONTROLS, INDICATORS AND CONNECTORS

2-2 Right Side Section (Cont'd)

12 Tape transport direction indicators

One of the indicators lights according to the tape transport direction.
← is displayed in the record-pause mode and in the still picture mode.

13 Remaining Battery Power Display

The 7-dot segment bar display shows the remaining battery power.

- To display the remaining battery power accurately, set the VCR Setup Menu item No. 396 BATTERY TYPE according to the type of the battery pack in use.

☞ See "Remaining Battery Power Display" on page 22.

14 Counter display

- Usually, this section shows the data of the CTL counter, time code or user's bit. The display mode can be selected with the ④ COUNTER switch.

- Displays the VCR setup menu data when the GY-DV500 is in the VCR setup menu mode by pressing the MENU button ① on page 15. The VCR setup menu includes the hour meter (accumulated drum operating time).

- This section shows an error code when an abnormal condition occurs with the unit.

☞ See "Counter Display Contents" on page 22.

☞ See "TROUBLES WITH ERROR CODE OUTPUTS" on page 90.

15 Section for time code related indications

■ [PB] Time code playback indicator

Lights when the time code is in playback mode.

■ [NDF] Non-drop frame indicator (U-ver. only)

Lights when the internal time code generator or the playback time code framing mode is non-drop frame. "DF" is displayed in the drop-frame mode.

- It never lights when the CTL counter is displayed.

■ [HOLD] indicator

Lights when the time code generator display is held by pressing the HOLD button in the time code setting block. The time code or user's bit can be preset while this indicator is lit.

☞ See "Displaying Time Code" on page 56.

16 Warning indicators

■ [AUTO OFF] indicator

Lights when a non-recoverable error (e.g. tape winding error, drum stopped, etc.) occurs with the unit. This indicator also lights if condensation occurs.

☞ See "TROUBLES WITH ERROR CODE OUTPUTS" on page 90.

■ [DEW] indicator

Lights when condensation (dewing) occurs on the drum or other mechanism in the unit.

The unit rejects all operations while this indicator is lit. When the condensation has disappeared, the indicator turns off and the unit accepts operations again.

■ [SERVO] indicator

Lights in the case of trouble with the drum servo during recording to indicate that normal recording is not being accomplished.

■ [RF] indicator

Lights when the video head is clogged. Head clogging is detected during playback and recording check using the RET button on the lens section. Note that it is not detected during recording.

* Should this indicator light up, clean the head using the provided head cleaning tape. For instructions on head cleaning tape, read the separate sheet "Precautions for Use of Head Cleaning Tape".

■ [Li] Lithium battery indicator

Lights and indicates the necessity of replacement when the lithium battery that backs up data of the built-in time code generator is nearly exhausted.

☞ See "Inserting and Replacing Backup Lithium Batteries" on page 34.

For servicing
The protocol of VCR control is not included in this service manual.

2. CONTROLS, INDICATORS AND CONNECTORS

2-3 Left Side Section

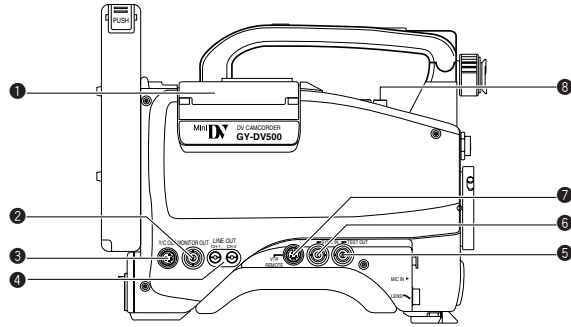

1 Cassette cover

Pressing the EJECT switch on top of the section opens this cover so that a videocassette can be inserted or removed from the unit. The cover can be locked automatically by pushing and closing it.

* If the cassette cover is not closed, the GY-DV500 will remain inoperative.

Memo:

To prevent penetration of foreign objects into the unit, do not leave the unit with the cassette cover open.

2 [MONITOR OUT] monitor output connector (BNC)

- Composite video signal output with setup (for U-ver.). Composite video signal output (E-ver.).
- An EE image or the playback image is output through the VCR section.

An EE image is output during other modes than the playback mode.

* Data for the Camera and VCR setup menus or time code is not output.

3 [Y/C OUT] connector (4P)

Separate YC video signal output connector.

4 [LINE OUT CH-1/CH-2] connector (RCA)

Output connector for audio signals.

- Outputs the input audio signal in the record and stop modes.
- Outputs the playback audio signal in the playback mode.
- Alarm sound is not output.

5 [TEST OUT] connector (BNC)

Composite video signal output connector. Outputs the camera image.

6 [SYNC.IN] connector (BNC)

For inputting the sync signal when the GY-DV500's camera image is synchronized with an external component.

Memo:

- The camera cannot be synchronized with a VCR playback signal.
- When the power is switched ON while an external sync signal is input, the screen moves in a vertical direction for a few seconds. This is not a malfunction.
- Only for the combined H (horizontal)/V (vertical) synchronizing signal. Synchronization with the SC (sub-carrier) of the input signal is not possible. Even if SC adjustment is performed, a phase shift will take place at the time of power on/off. The SC phase must be adjusted each time the power is turned on.
- Color frame synchronization is not possible.
- If the external sync signal is disrupted during recording, the "SYNC INH" (SYNC INHIBIT) indicator is displayed on the counter display and recording stops.
- If the external sync signal is disrupted during playback, playback of the disturbed video image continues. Start playback again after synchronization is obtained and the signal is stabilized.

7 [VTR REMOTE] connector

A part of the unit's functions can be controlled externally. To remote control the unit using the control signal of this connector, the VCR Setup Menu item No. 050 REMOTE SELECT must be set to "RS232C". For details, please consult your JVC dealer.

Note:

- When a cable is connected to the VTR REMOTE connector, the VTR Setup Menu is not displayed in the viewfinder. Make settings on the VTR Setup Menu while the cable is not connected.
- When a cable is connected to the VTR REMOTE connector, the VCR operation mode will not be displayed correctly on the Status 1 screen in the viewfinder.

8 Microphone attachment holes

For attaching the microphone holder KA-A50 (optional).
* See "Attaching the Microphone (optional)" on page 32.

2. CONTROLS, INDICATORS AND CONNECTORS

2-4 Top Section

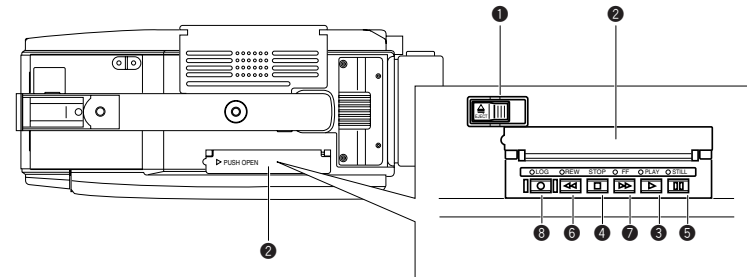

1 [EJECT] switch

Slide to the side when inserting or ejecting the videocassette. Sliding this switch opens the cassette cover. If the switch is moved while the power is off, the cassette cover opens but it is not possible to insert or eject the cassette.

2 Operation cover

Open this cover when operating in the playback mode. Otherwise, keep this cover closed.

3 [PLAY] button

Press to start playback. In play mode, the unit outputs the video and audio signals of normal playback and the LED indicator above the PLAY button lights.

* If the auto tracking is active at the moment the play mode is entered, the playback video will be interfered with digital noise.

4 [STOP] button

Press to enter stop mode. The drum keeps rotating in stop mode. However, when stop mode has continued for about 30 minutes, the unit enters the tape protect mode, in which the drum stops rotation and the tape tensioner is released. It takes more time than usual to enter the record or play mode from the tape protect mode.

* The time until the tape protect mode is initiated can be set to 3 or 30 minutes with the VCR Setup Menu item No. 307 LONG PAUSE TIME. When used in a cold environment, the setting will be 3 minutes regardless of the setting on the VCR Setup Menu.
* See page 69.

5 [STILL] button

Press to enter the still picture mode during playback or in the search mode.

When the still picture mode has continued for about 30 minutes, the unit automatically switches to the stop mode. (Tape protect mode)

* The time until the tape protect mode is initiated can be set to 3 or 30 minutes with the VCR Setup Menu item No. 307 LONG PAUSE TIME.

When used in a cold environment, the setting will be 3 minutes regardless of the setting on the VCR Setup Menu.

6 [REW] button

Press to rewind the tape.

- Pressing the button in stop or fast forward mode initiates the rewind mode. The LED indicator above the REW button lights in this mode.
- Pressing the button during playback, still or forward search initiates reverse search at about 10 times the normal play speed. The LED indicators above the PLAY and REW buttons light during reverse search.

7 [FF] button

Press to fast forward tape.

- Pressing the button in stop or rewind mode initiates fast forward mode. The LED indicator above the FF button lights in this mode.
- Pressing the button during playback, still or reverse search initiates forward search at about 10 times the normal play speed. The LED indicators above the PLAY and FF buttons light during forward search.

8 [LOG] button

- When the REW button is pressed while this button is kept pressed, the S.S.F. data stored in the unit's memory are written to the tape. The LED indicator above the LOG button lights while S.S.F. data is being written to the tape.
- When the CONTINUE button (● on page 15) is pressed while this button is kept pressed in the stop mode, the tape winds to the S.S.F. data's last OUT point, after which the unit enters the record-pause mode. (Scene End Cue Up)

The FF button's LED blinks during Scene End Cue Up.
* See "Writing S.S.F. Data to Tape" on page 63.

CAUTION:

- Only the EJECT switch and STOP button work during recording.
- If the cassette cover is open, all operations are rejected.

2. CONTROLS, INDICATORS AND CONNECTORS

2. CONTROLS, INDICATORS AND CONNECTORS

2-5 Rear Section

2-5 Rear Section (Cont'd)

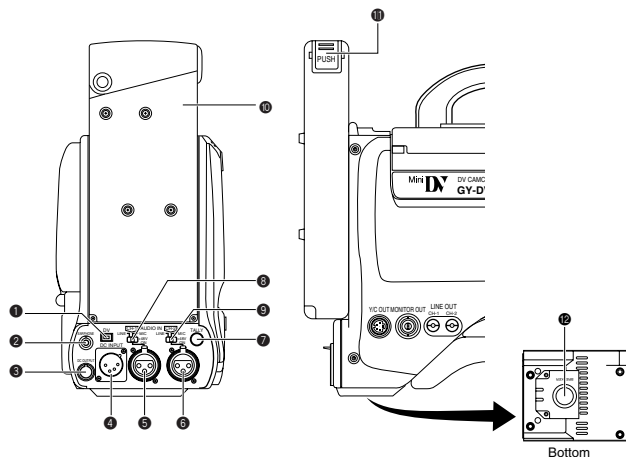

1 [DV] connector

Using a DV cable (optional), a digital video component with DV connector can be connected here.

This connector is used for input and output of the DV signal or to input the VCR control signal from the digital video component with DV connector.

- To record the DV signal from this connector, set the VCR Setup Menu item No. 126 INPUT SELECT to "IEEE1394".
 - To remote control the VCR with a VCR control signal from this connector, set the VCR Setup Menu item No. 050 REMOTE SELECT to "IEEE1394".
- The setup level signal for the DV output connector is not provided. (NTSC only)

2 [EAR.] earphone jack

This is a stereo mini-jack for connecting an audio monitoring earphone. Plug in an earphone or headphone with a 3.5 mm diameter plug. (Monaural mini jack)

The earphone can also be used to monitor alarm tones depending on situations.

The sound from the monitoring loudspeaker is interrupted when an earphone is connected here.

Memo:

Only the left-channel sound is heard when a stereo mini-jack is used.

3 [DC OUTPUT] connector

Power output connector to a wireless microphone transmitter, etc. The supply voltage is identical to the voltage supplied to the unit (DC 12V max. 0.1 A).

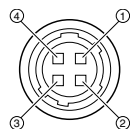

(Surface profile)

No.	Signal
1	GND
2	—
3	—
4	DC +12V (power through)

4 [DC INPUT] connector (XLR 4-pin)

Power input connector for 12 V DC. Connect with the AA-P250 optional AC power adapter. When a cable is connected here, the power supply from the battery pack is interrupted and the source is switched to the power supplied through this connector.

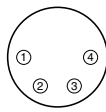

No.	Signal
1	GND
2	—
3	—
4	+12V

5 [CH-1 AUDIO IN] CH-1 audio input connector (XLR 3-pin)

Connect the external audio equipment or microphone to this connector. Set the CH-1 AUDIO IN LINE/MIC select switch 6 according to the connected equipment.

The audio signal input through this connector is recorded on the CH-1 audio channel. To record the audio of this connector, set the CH-1 AUDIO INPUT switch 7 on page 14 to "REAR".

(AUDIO IN connector)

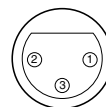

No.	Signal
1	GND
2	HOT
3	COLD

6 [CH-2 AUDIO IN] CH-2 audio input connector (XLR 3-pin)

Connect the external audio equipment or microphone to this connector. Set the CH-2 AUDIO IN LINE/MIC select switch 8 according to the connected equipment.

The audio signal input through this connector is recorded on the CH-2 audio channel. To record the audio of this connector, set the CH-2 AUDIO INPUT switch 9 on page 14 to "REAR".

7 Back tally lamp

This lamp lights up when the GY-DV500 enters the record mode. It blinks during the transition to the record mode.

- Use the VCR Setup Menu item No. 082 BACK TALLY MODE to select whether or not the lamp should light and the lighting pattern.
- ☞ See "BACK TALLY MODE" on page 68.

8 [CH-1 AUDIO IN LINE/MIC] CH-1 AUDIO select switch

Selects the audio signal input to the 5 CH-1 AUDIO IN connector.

LINE : Set to this position when connected to audio equipment, etc. The reference input level is +4 dBs.

MIC : Set to this position when the microphone is connected. The reference input level is -60 dBs.

MIC +48V ON:

Set to this position when the microphone requiring +48 V power supply (phantom microphone, etc.) is connected.

This connector supplies +48 V DC current.

9 [CH-2 AUDIO IN LINE/MIC] CH-2 AUDIO select switch

Selects the audio signal input to the CH-2 AUDIO IN connector 6.

LINE : Set to this position when connected to audio equipment, etc. The reference input level is +4 dBs.

MIC : Set to this position when the microphone is connected. The reference input level is -60 dBs.

MIC +48V ON:

Set to this position when a microphone requiring +48 V power supply (phantom microphone, etc.) is connected. This connector supplies +48 V DC current.

CAUTION:

When connecting a component that does not require +48 V power supply, make sure that the switch is not set to this position before the connection is made.

10 Battery holder

Mount a Flat Shape type battery pack here.

☞ See "Attaching a Flat Shape Type Battery Pack" on page 36.

11 Battery holder lock release knob

This knob is used to open the battery case cover. Press the knob to open the cover.

12 [BRAKER]

The braker trips when the power consumption exceeds the capacity.

If the braker trips, confirm that the power consumption does not exceed the wattage rating. Then press BRAKER before turning the power ON again to put the camera in the operating status.

If the unit still does not work normally, please consult the person in charge of professional video equipment at your nearest JVC-authorized service agent.

2. CONTROLS, INDICATORS AND CONNECTORS

2. CONTROLS, INDICATORS AND CONNECTORS

2-6 Counter Display Contents

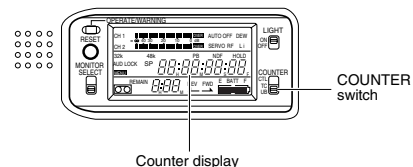

Counter display

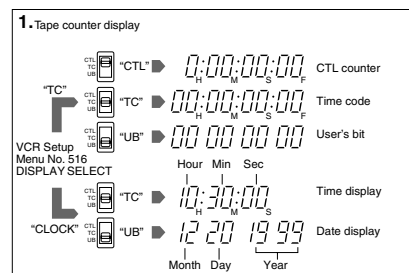

Remaining Tape Time Display

This display shows the remaining tape time (minutes/seconds) in record and play modes.

- Example: 30 minutes of remaining tape.

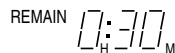

- This indicator blinks when remaining tape time is equivalent to less than 2 minutes.
- An alarm sounds as a warning when remaining tape time is equivalent to less than 2 minutes in the record mode

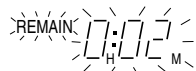

- The following display appears when no videocassette is loaded or during the calculation of remaining tape that takes place immediately after a videocassette is inserted.

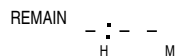

The counter display shows the following 4 types of information.

1. Tape counter display

The counter display usually functions as a tape counter (hour, minute, second, frame). It can be switched to a CTL counter, time code or user's bit display by using the COUNTER switch. (When the VCR Setup Menu item No. 516 DISPLAY SELECT is set to "TC".)

- **CTL counter:** Time between -9 hr. 59 min. 59 sec. 29 frames and 9 hr. 59 min. 59 sec. 29 frames can be displayed. Running mode is fixed as non-drop frame.

* CTL counter indication may also corrupt at playback of segment which time code signal is not continuously recorded.

- **Time code** : Time between 0 hour and 23 hr. 59 min. 59 sec. 29 frames can be displayed.
- **User's bit** : Hexadecimal number from 0 to F is displayed in 8 digits.

When the VCR Setup Menu item No. 516 DISPLAY SELECT is set to "CLOCK", the date and time are displayed. Set the COUNTER switch to TC or UB.

- **TC:** Time (Hour, Min., Sec.) is displayed.
- **UB:** Date (Month, Day, Year) is displayed.
- Press the MENU button to switch to the VCR Setup Menu setting display.

2. VCR Setup Menu setting display

This display is used when setting the setup menus. After setting of the setup menus, the tape counter display returns. For details, see "DISPLAYING AND SETTING VCR SETUP MENUS" on page 67.

3. Hour meter display

The hour meter is displayed by selecting the HM group from the VCR Setup Menu. The hour meter data refers to the accumulated head drum running time.

4. Error code/Alarm display

The error code or alarm indicator is displayed automatically in case an abnormal condition occurs with the unit.

- ☞ See "TROUBLES WITH ERROR CODE OUTPUTS" on page 90.
- ☞ See "ALARM INDICATIONS" on page 86.

Remaining Battery Power Display

The 7-dot segment bar display shows the remaining battery power. The lighted segment bars decrease as the remaining battery power decreases.

- To display the remaining battery power accurately, set the VCR Setup Menu item No. 396 BATTERY TYPE according to the type of the battery pack in use.

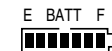

All segment bars light when a fully charged battery pack is attached.



The last 2 segment bars and "BATT" start to blink when the battery is nearly exhausted. Replace with a fully charged battery pack.



When the battery capacity has run out, "E" and "BATT" blink and the unit stops operation automatically.

2-6 Counter Display Contents

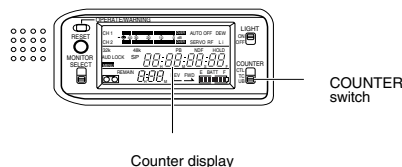

Counter display

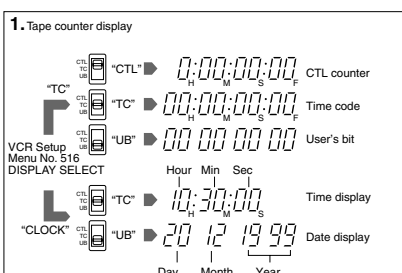

Remaining Tape Time Display

This display shows the remaining tape time (minutes/seconds) in record and play modes.

- Example: 30 minutes of remaining tape.

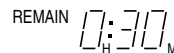

- This indicator blinks when remaining tape time is equivalent to less than 2 minutes.
- An alarm sounds as a warning when remaining tape time is equivalent to less than 2 minutes in the record mode



- The following display appears when no videocassette is loaded or during the calculation of remaining tape that takes place immediately after a videocassette is inserted.

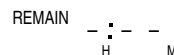

The counter display shows the following 4 types of information.

1. Tape counter display

The counter display usually functions as a tape counter (hour, minute, second, frame). It can be switched to a CTL counter, time code or user's bit display by using the COUNTER switch. (When the VCR Setup Menu item No. 516 DISPLAY SELECT is set to "TC".)

- **CTL counter:** Time between -9 hr. 59 min. 59 sec. 24 frames and 9 hr. 59 min. 59 sec. 24 frames can be displayed.

* CTL counter indication may also corrupt at playback of segment which time code signal is not continuously recorded.

- **Time code** : Time between 0 hour and 23 hr. 59 min. 59 sec. 24 frames can be displayed.
- **User's bit** : Hexadecimal number from 0 to F is displayed in 8 digits.

When the VCR Setup Menu item No. 516 DISPLAY SELECT is set to "CLOCK", the date and time are displayed. Set the COUNTER switch to TC or UB.

- **TC:** Time (Hour, Min., Sec.) is displayed.
- **UB:** Date (Day, Month, Year) is displayed.
- Press the MENU button to switch to the VCR Setup Menu setting display.

2. VCR Setup Menu setting display

This display is used when setting the setup menus. After setting of the setup menus, the tape counter display returns. For details, see "DISPLAYING AND SETTING VCR SETUP MENUS" on page 67.

3. Hour meter display

The hour meter is displayed by selecting the HM group from the VCR Setup Menu. The hour meter data refers to the accumulated head drum running time.

4. Error code/Alarm display

The error code or alarm indicator is displayed automatically in case an abnormal condition occurs with the unit.

- ☞ See "TROUBLES WITH ERROR CODE OUTPUTS" on page 90.
- ☞ See "ALARM INDICATIONS" on page 86.

Remaining Battery Power Display

The 7-dot segment bar display shows the remaining battery power. The lighted segment bars decrease as the remaining battery power decreases.

- To display the remaining battery power accurately, set the VCR Setup Menu item No. 396 BATTERY TYPE according to the type of the battery pack in use.



All segment bars light when a fully charged battery pack is attached.



The last 2 segment bars and "BATT" start to blink when the battery is nearly exhausted. Replace with a fully charged battery pack.



When the battery capacity has run out, "E" and "BATT" blink and the unit stops operation automatically.

2. CONTROLS, INDICATORS AND CONNECTORS

2-7 Lens (optional)

[S14 x 7.3B12]

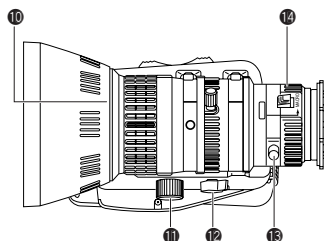
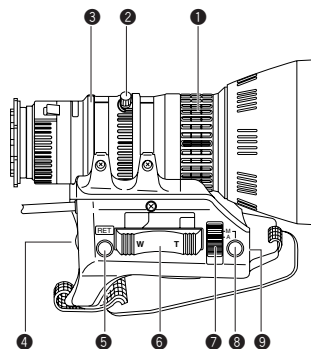

- 1 FOCUS ring**
Manual focus ring.
- 2 ZOOM lever/ring**
This is the manual zoom ring equipped with a zoom lever. To adjust the zoom manually, turn the zoom mode knob **12** to position "M".
- 3 IRIS ring**
Manual iris ring. To activate the auto iris feature, set the Iris Mode switch **7** to A.
- 4 [VTR] Trigger button**
To start/stop shooting.
- 5 [RET] return video button**
The return video signal from the VCR section can be monitored in the viewfinder only while this button is pushed.
* The playback picture can be viewed in the viewfinder during this operation.
- 6 ZOOM servo control lever**
To operate the servo zoom feature with this lever, set the ZOOM knob **12** to S.
 - Pressing the W section of this lever increases the angle of the lens for a wider shooting angle.
 - Pressing the T section of this lever narrows the lens angle perspective for telephoto shots.
 - Pushing harder changes the speed of the zoom.

- 7 IRIS mode switch**
A: Activates the auto iris feature.
M: Allows manual iris control.
- 8 Momentary auto iris button**
When the IRIS MODE switch **7** is at "M", pushing this button activates the Auto Iris Function while it is held down only.
- 9 [S] IRIS speed adjusting control**
For adjusting the iris operation speed.

Memo:

- If the speed becomes too fast, hunting may occur.
- To avoid the phenomena described above, perform adjustment again.

- 10 FILTER thread**
Protect the lens with a clear filter or UV filter by screwing the filter onto the thread inside the lens hood from the front. Other filters can be used for various effects.

CAUTION:

The filter thread section rotates, so pay attention when mounting a polarizing filter.

- 11 ZOOM servo connector**
Connect an optional zoom servo unit here.
- 12 ZOOM mode knob**
S: Servo zoom mode. Allows operation by the zoom servo control lever **6**.
M: Manual zoom mode. Allows zoom control by the zoom lever/ring **2**.
- 13 BACK FOCUS ring/fixing screw**
For back focus adjustment only. Secure with the screw knob after adjustment.
☞ See "Back Focus Adjustment" on page 44.
- 14 Macro focusing ring (for close-up shooting)**
By rotating this ring in the direction of the arrow, close-up shooting of very small objects becomes possible.
Normal focus adjustment and zooming are not available in the macro mode.
To shoot images in the macro mode, set the focus ring **1** to the infinite position and the zoom ring **2** to the maximum wide-angle position. To adjust the focus of the macro image, rotate this ring in the direction of the arrow until the object is focused.

CAUTION:

- The back-focus knob is located close to the macro ring, be careful not to mistake the back-focus knob for the macro ring.
- After the required operation, be sure to return the macro focusing ring to the normal position.

☞ See "Attaching the Zoom Lens (optional)" on page 31.

☞ See "Back Focus Adjustment" on page 44.

2. CONTROLS, INDICATORS AND CONNECTORS

2-8 1.5-Inch Viewfinder (optional)

[VF-P115B]

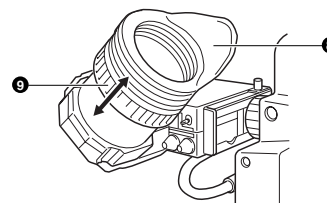
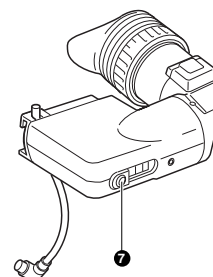
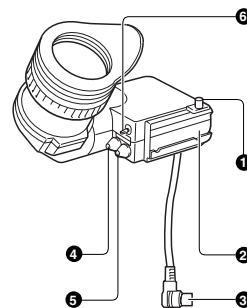

- 1 Stopper screw**
This screw prevents the viewfinder from coming off the camera.
- 2 Mounting guide**
To attach on the camera.
- 3 Connector**
Connect to the camera.
- 4 [CONT] contrast adjustment**
To adjust the contours of the viewfinder image.
- 5 [BRIGHT] brightness adjustment**
To adjust the brightness of the viewfinder.
- 6 [TALLY] switch**
Set this switch to OFF to prevent the tally light **7** from turning on and informing people that they are being recorded. However, the REC indicator lamp in the eyepiece will not turn off.
- 7 Tally light**
Lights when recording is in progress. To prevent this light from coming on, set the tally switch **6** to "OFF".
- 8 Eyepiece**
Ensures that ambient light does not reach the viewfinder screen or falls into the eye of the cameraman. The eyepiece can be opened to allow direct observation of the viewfinder screen.
- 9 Eyepiece focusing ring**
Loosen this ring to move the eyepiece back or forth to adjust the diopter.

2. CONTROLS, INDICATORS AND CONNECTORS

2-9 Indications in Viewfinder

■ WARNING LED INDICATORS INSIDE THE VIEWFINDER

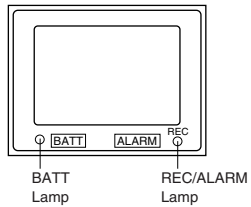

The viewfinder has two LED indicators below the screen. These LEDs light or blink to indicate the present status of the camera or the VCR.

- **[BATT] battery lamp**
This lights red when the battery voltage becomes too low for operating the camera.
- **REC/ALARM lamp**
This lights or blinks green under the following circumstances.
Steady green : During recording.
Blinks green : • While the GY-DV500 switches from record-pause to recording.
• Immediately before the tape is running out or when it has run out.
• When an error occurs in the GY-DV500.

■ VIEWFINDER SCREEN DISPLAY

The following indications are displayed on the viewfinder screen. (However, this information is not displayed while the VCR section is playing back a tape.)

- Status screens (screens for use in checking the current camera settings)
- Alarm message display
- Safety zone display
- Setting screen (screen for use in the camera and VCR setup)
- Auto white balance display
- Shutter speed display

■ Status Screens

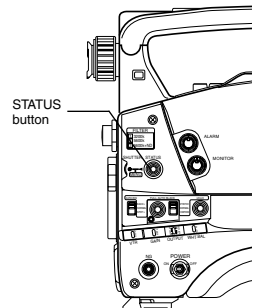

Press the STATUS button during normal screen display to show one of the status screens in the viewfinder. One of the three status screens will be displayed every time the button is pressed.

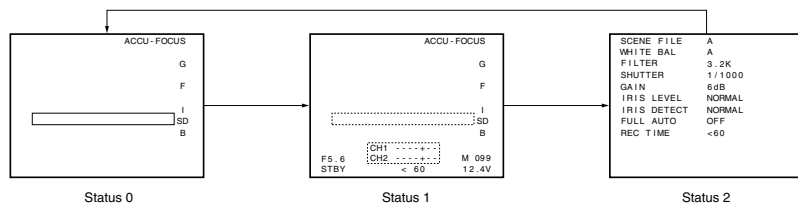

2. CONTROLS, INDICATORS AND CONNECTORS

2-9 Indications in Viewfinder (Cont'd)

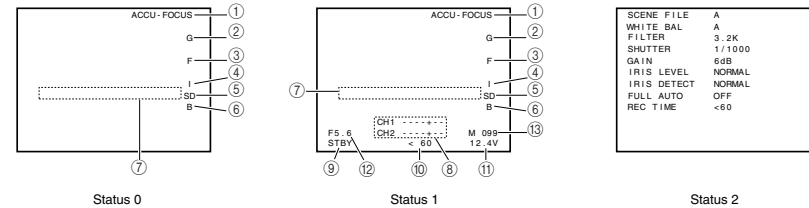

● Status 0

Display Position	Display	Function
①	ACCU-FOCUS	Blinks during the ACCU-FOCUS operation.
	SKIN AREA	Blinks while the skin tone detail color area is displayed.
	S	Displayed when the SHUTTER or V-SCAN is ON.
	FAS	Displayed when the Full Auto Shooting is ON.
	ALC	Displayed when the ALC alone is ON.
②	G	Displayed in other modes than 0 dB, LOLUX and ALC.
	L	Displayed during LOLUX operation.
③	F	Displayed when FAW alone is ON.
④	I	Displayed when IRIS BACK LIGHT or IRIS SPOT LIGHT is selected.
⑤	SD	Displayed while the Skin Detail function is in operation.
⑥	B	Displayed when BLACK STRETCH or BLACK COMPRESSION is selected.
⑦	Event display	See the table below.

⑦ Event display

Event is displayed in the viewfinder for only about 2 seconds when any of the following switches is operated.

Switch	Event Display Contents	
ZEBRA	ZEBRA	ON, OFF
BLACK	BLACK	STRETCH, NORMAL, COMPRESS
GAIN	GAIN	-3 dB, 0 dB, 6 dB, 9 dB, 12 dB, 18 dB, ALC
WHT. BAL	WHITE BAL	A, B, PRESET, FAW
FULL AUTO	FULL AUTO	ON, OFF
AUTO IRIS	IRIS	BACK.L, NORMAL, SPOT.L
LOLUX	LOLUX	ON, OFF
FILTER knob	FILTER	3.2K, 5.6K, 5.6K+ND
VTR	VTR	STBY, SAVE
AUTO KNEE	AUTO KNEE	ON, OFF

2. CONTROLS, INDICATORS AND CONNECTORS

2-9 Indications in Viewfinder (Cont'd)

● Status 1

In addition to the information on the Status 0 screen, this screen displays audio indicators and information on remaining tape, voltage and lens F-number.

Display position	Display	Function
⑧	(Example) CH1- ---- + -- CH2- ---- + --	Shows the input level of the audio input channel. Display ON/OFF can be selected using the VF DISPLAY menu screen. ☞ See "AUDIO DISPLAY" on page 72.
⑨	STBY SAVE STOP REC FF REW EJECT	VCR in standby mode VCR in save mode VCR in stop mode VCR in record mode VCR in fast-forward mode VCR in rewind mode VCR in reverse search mode Note: When the RS-232C cable is connected, the VCR operation mode may not be displayed correctly.
⑩	(Example) < 60 (Example) 12: 34: 56: 20	Remaining tape indication (displayed in 1-minute steps) When the tape is used for a long time, the remaining tape may not be indicated accurately. At the beginning of the tape, in particular, the indication may show smaller value than the actual one. Time code display Time code display is available when the "REC TIME" item on the VF DISPLAY menu screen is set to TIME CODE. ☞ See "REC TIME" on page 72.
⑪	(Example) 12.4V	Voltage indication (displayed in 0.1 V steps)
⑫	OPEN, F2, F2.8, F4, F5.6, F8, F11, F16, CLOSE	Shows the F-number of the connected lens. It is not displayed when the lens is removed. For some lenses, no display appears. Display ON/OFF can be selected on the VF DISPLAY menu screen. ☞ See "F NO.DISPLAY" on page 72.
⑬	(Example) M:99	In the Super Scene Finder (S.S.F.) mode, the number of memorized scenes is shown. M: In MARK mode C: In CUE mode Number: Number of memorized scenes

● Status 2

This screen displays the camera setup statuses.
Event display is not available while this screen is displayed.

Indication	Indication Contents
SCENE FILE	A, B, OFF
WHITE BAL	A, B, PRESET, FAW
FILTER	3.2K, 5.6K, 5.6K+ND
SHUTTER	OFF, 1/100, 1/250, 1/500, 1/1000, 1/2000, 1/60.1 to 1/2084.6 (in VARIABLE mode), EEI (in ALC mode)
GAIN	-3dB, 0dB, 6dB, 9dB, 12dB, 18dB, LOLUX, ALC
IRIS LEVEL	NORMAL, BACK L, SPOT L
FULL AUTO	ON, OFF
REC TIME	Remaining tape time or time code.

2. CONTROLS, INDICATORS AND CONNECTORS

2-9 Indications in Viewfinder (Cont'd)

■ Alarm Message Display

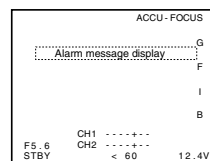

The following alarm messages are displayed on the status 0 and status 1 screens.

Indication	Contents
LOW BATTERY CLOSE CASSETTE COVER	The battery capacity is nearly exhausted. The cassette cover is not closed.
VTR WARNING [HEAD] VTR WARNING [SERVO] VTR WARNING [DEW] VTR WARNING [HARD] VTR WARNING [STOP] VTR WARNING [REW]	Head clogging Servo error Condensation Hardware error Operation stopped Rewinding abnormality
TAPE NEAR END TAPE END REC INHIBIT	Remaining tape time is less than about 2 minutes in the record mode Tape end reached An unrecordable videocassette (the switch on the back of the cassette is set to SAVE) is inserted.
NO TAPE	VTR trigger is pressed with no tape loaded.

2. CONTROLS, INDICATORS AND CONNECTORS

2-9 Indications in Viewfinder (Cont'd)

■ Safety Zone

Three types of safety zone items can be displayed in the viewfinder. Select the required one with the SAFETY ZONE item on the VF DISPLAY menu screen.

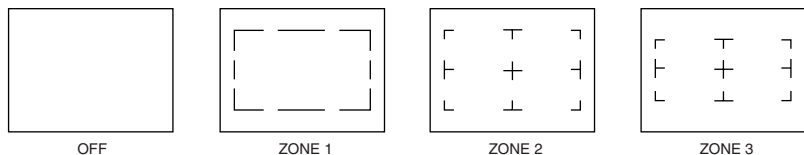

■ Setting the Screen Display

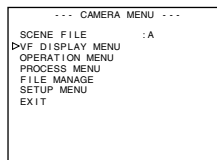

Screen used for making various settings of the camera and VCR.

☞ See "Camera Menu Screen Flow" on page 70.

☞ See "VCR Setup Menu" on page 66.

■ Auto White Balance Display

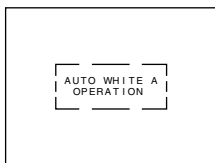

This screen appears during the auto white balance adjustment operation to display various data.

☞ See "White Balance Adjustment" on page 45.

■ Shutter Speed Display

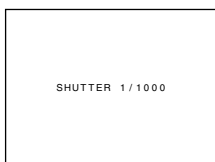

When the SHUTTER dial is pressed, a shutter speed is displayed (for approx. 5 sec.).

In addition, whenever the shutter speed is altered by using the SHUTTER dial, the shutter speed is displayed. While this display is shown, other displays disappear.

☞ See "SHUTTER/MENU dial" on page 12.

3. BASIC SYSTEM CONNECTIONS AND ADJUSTMENTS

3-1 Basic System

For information on connection with the individual attachments, refer to the page explaining the respective connection methods.

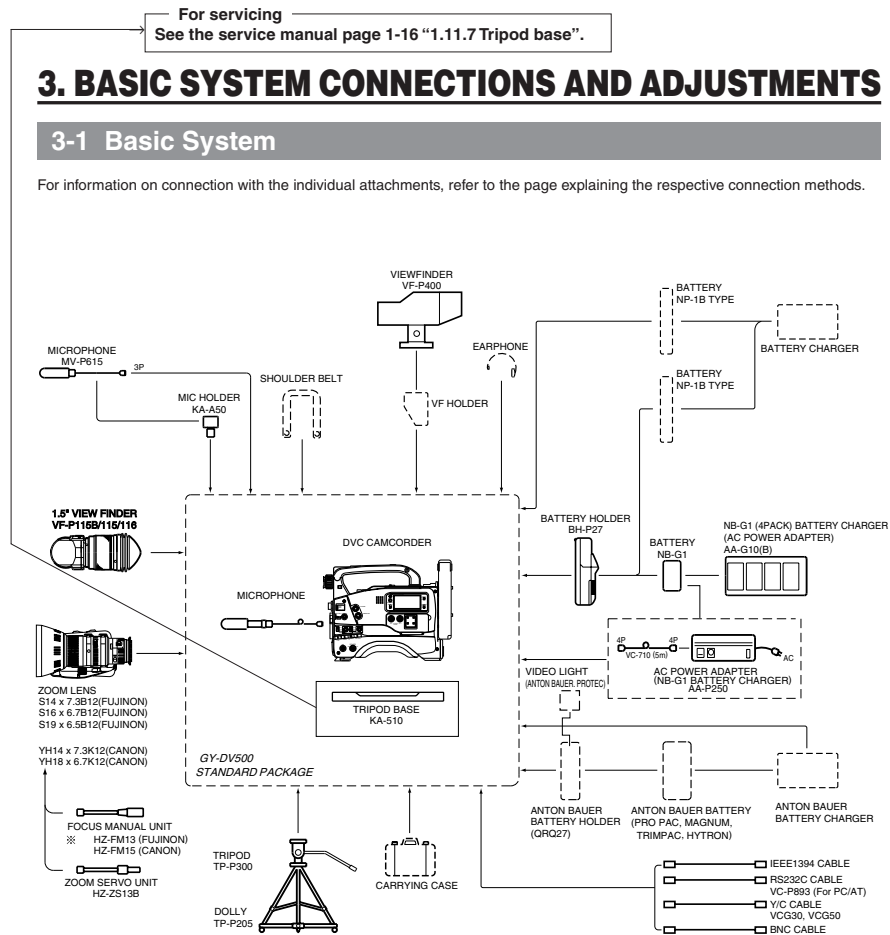

* HZ-FM13 cannot be used with S14X7.3B12/U.

Please use the Focus Manual Unit (FMM-8, CHF-3, CFC-12-990) manufactured by Fujinon.

3. BASIC SYSTEM CONNECTIONS AND ADJUSTMENTS

3-2 Attaching the Zoom Lens (optional)

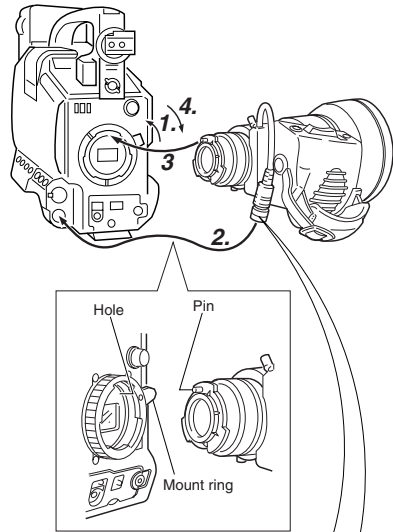

1. Loosen the mount ring.
2. Connect the cable connector.
3. Attach the lens with its pin aligned with the hole in the mount.
4. Tighten the mount ring.

CAUTION:
Be sure to tighten the mount ring completely. Incomplete tightening may result in the lens dropping off or disturbed back focus.

When unplugging the cable connector, first remove the lens itself. Then grasp this portion and pull straight out.

3-3 Attaching the Viewfinder

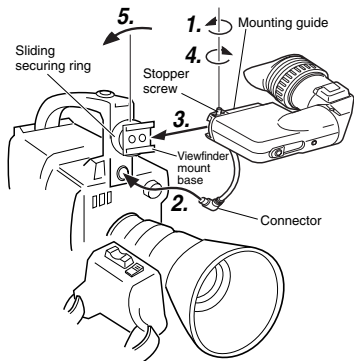

1. Loosen the stopper screw on the viewfinder.
2. Connect the connector.
3. Align the mounting guide with the camera's viewfinder mount base and attach the viewfinder.
4. Tighten the stopper screw.
5. Tighten the sliding securing ring.

* To detach the viewfinder, reverse the mounting procedure.

3. BASIC SYSTEM CONNECTIONS AND ADJUSTMENTS

3-4 Attaching the Microphone (provided)

Provided Microphone

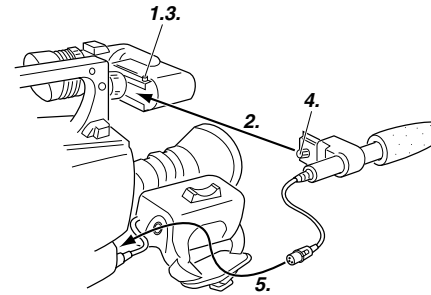

Connecting the provided microphone to the viewfinder. The provided microphone is a phantom microphone.

1. Loosen the stopper screw on the viewfinder.
2. Attach the microphone to the attachment guide on the viewfinder as illustrated.
3. Confirm that there is no gap between the microphone and the viewfinder, and then tighten the stopper screw.
4. Tighten the microphone screw. The microphone should be firmly attached.
5. Connect the cable from the microphone to the MIC IN connector on the front section of the camera.
6. Secure the microphone cable using the cable clamp provided on the front side of the microphone holder.

CAUTION:
When this microphone is attached, the range that the viewfinder can be moved to the left will be reduced. Please purchase a separately sold microphone if you prefer to observe through the viewfinder using your left eye.

3-5 Attaching the Microphone (optional)

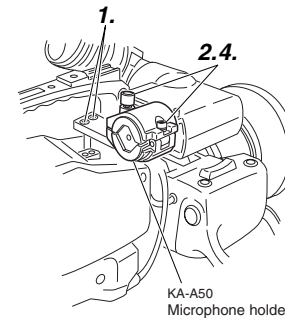

With the optional KA-A50 microphone holder, the optional microphones MV-P615 (Phantom microphone) can be used.

■ Attaching the Microphone with KA-A50

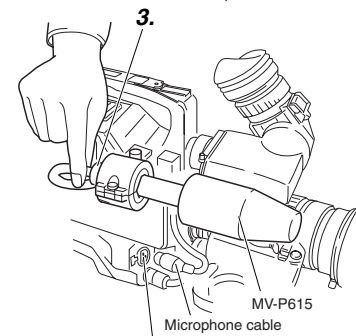

1. Secure the microphone holder with 2 screws.
2. Turn the small knob located on the outer side of the microphone holder anticlockwise to loosen it, and loosen the large knob located on the inner side in the same way. Rotate the large knob fully anticlockwise to open the holder.
3. Attach the microphone to the microphone holder so that the microphone does not interfere with the cassette cover.
4. Set the microphone holder so that the height is level, and tighten the inside and outside knobs to secure the microphone.
5. Connect the microphone cable to the MIC IN input connector.
 - When the microphone is connected to CH-1 AUDIO or CH-2 AUDIO connector on the rear panel, set the CH-1 or CH-2 Audio select switch according to the microphone used.
6. Secure the microphone cable using the cable clamp provided on the front side of the microphone holder.
7. Make sure to perform the correct settings for use of a phantom microphone.
 - ☞ See "CAM MIC +48V" on page 77.

Note:
• When the light mounted on the camera is used at the same time, if the microphone in use has a long sound collecting section (ultra-directional type, etc.), the microphone's shadow may influence the image.

For servicing
See the service manual page 1-16 "1.11.7 Tripod base".

3. BASIC SYSTEM CONNECTIONS AND ADJUSTMENTS

3-6 Attaching the Tripod Base (provided)



1. Tripod mounting holes

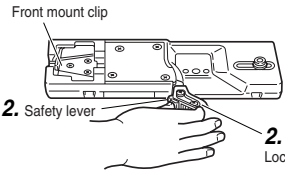

2. Safety lever
2. Lock lever

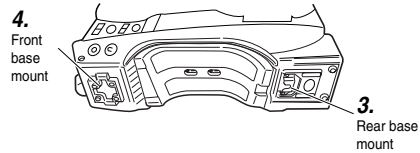

4. Front base mount
3. Rear base mount

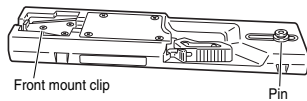

Front mount clip
Pin

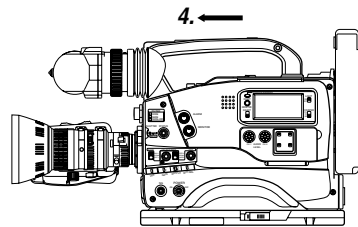

4. —

Use the provided tripod base to place the camera on a tripod.

1. Attach the tripod base on the tripod by using the hole that balances the unit most optimally.
2. While pushing the safety lever, pull the lock lever toward the front until the front mount clip clicks into place.
3. Place the unit on the tripod base by aligning the rear base mount of the unit with the pin on the tripod base.
4. Push the unit from the upward direction and slide it toward the front so that the front base mount of the unit is locked by the front mount clip of the tripod base as it clicks into place.

CAUTION:

- The front base mount may be locked while the pin of the tripod base is not inserted into the hole on the rear base mount of the unit. Therefore, after mounting, make sure that these parts are engaged properly.
- When moving the unit mounted on a tripod, any impact or vibration should be avoided as this may cause the unit to become detached and to drop from the tripod. Be sure to remove the unit from the tripod before transporting it.

3. BASIC SYSTEM CONNECTIONS AND ADJUSTMENTS

3-7 Inserting and Replacing Backup Lithium Batteries

The GY-DV500 uses a lithium battery for backup of the time code data. Install the provided lithium battery before actually using the unit.

- **Lithium battery: CR2032**

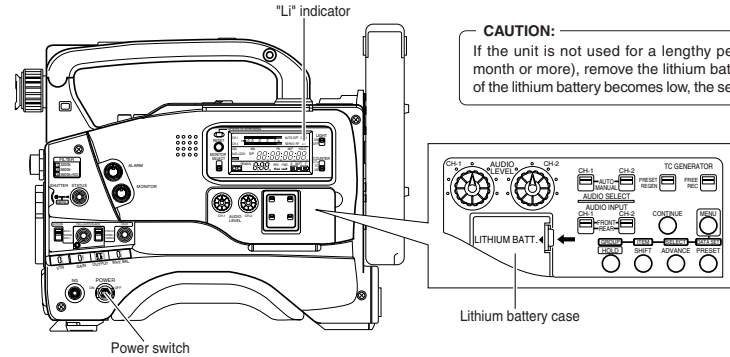

CAUTION:
If the unit is not used for a lengthy period of time (one month or more), remove the lithium battery. If the voltage of the lithium battery becomes low, the set may malfunction.

When the lithium battery is not in place or the battery is exhausted and requires a replacement, the "Li" indicator in the LCD display will light up.

Replace lithium batteries with the POWER switch set to ON. Doing it with the POWER switch set to OFF will cause the loss of backup data.

■ **How to Install the Lithium Battery**

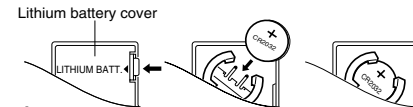

1. Push the lithium battery cover in the direction of the arrow as illustrated and remove the cover.
2. Slide the battery into place with its ⊕ marked surface facing upward.
3. Return the lithium battery cover to its original position in the unit.

■ **How to Remove Lithium Batteries**



- The lithium battery is easily removed if you press at the edge of the lithium battery at the place indicated in the illustration on the left and then pull the battery out.

After replacing the lithium battery, set the date and time.
To do this, see page 41 "Setting the Date and Time".

4. POWER SUPPLY

The GY-DV500 is operable with AC power supply or battery pack.

4-1 AC Operation

Use the JVC AA-P250 AC power adapter (max. rated output 12.5 V DC, 3.5 A) as the AC power supply.

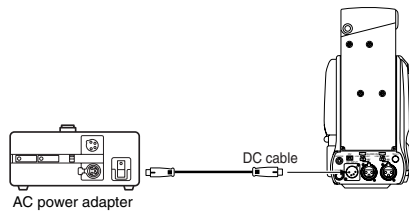

AC power adapter

Do not use any power source with large fluctuations in the power source voltage, or power sources generating noise, such as ripples.

1. After making sure that the power switches of the GY-DV500 and of the AA-P250 are set to OFF, connect the DC cable from the AA-P250 to the DC INPUT connector of the GY-DV500 as shown in the illustration.
2. When the AA-P250 is used, set the CHARGE/CAMERA switch to CAMERA.
3. Press the POWER switch of the GY-DV500 to ON. Power is supplied to the VCR section and the camera.
* For details, read the instruction manual of the AA-P250.

Note:

Do not remove or connect the DC cable while recording is being performed.

4-2 Battery Pack Operation

The GY-DV500 can be operated with the following battery packs.

- Flat shape type battery pack
- Anton-Bauer battery pack
 - Propack 13/14 Series
 - Trimpack 13/14 Series
 - Magnum 13/14 Series
 - Compact 13/14 Series

* An Anton-Bauer battery pack cannot be connected directly to the GY-DV500. It is necessary to mount the optional battery holder.
Battery holder: Anton-Bauer QRQ27
For details, see page 37 "Using an Anton-Bauer Battery Pack".

- When the DC cable is connected to the DC INPUT connector, the power supply from the battery pack is interrupted and the power starts to be supplied through the DC INPUT connector.
- Do not connect or disconnect the DC cable while operating with a battery pack.
The following symptoms may occur if the DC cable is connected or disconnected while operating with a battery pack.
 - The power is cut off for a moment when the DC cable is disconnected.
 - Noise to the video and audio signals occurs. Audio signal are muted.
- When operation is continued with DC input after the battery pack capacity has been used up, set the POWER switch to OFF after the DC power is applied. Then switch ON again.
- If the GY-DV500 is left with the battery pack attached, a small amount of power is consumed even if the POWER switch on the GY-DV500 is set to OFF. Remove the battery pack when the GY-DV500 is not going to be used.

4. POWER SUPPLY

4-2 Battery Pack Operation (Cont'd)

Attaching a Flat Shape Type Battery Pack

1. Open the battery case cover while pushing the lock release lever.
2. Insert the battery pack into the battery case with its electrodes facing the unit.
3. Close the battery case cover.

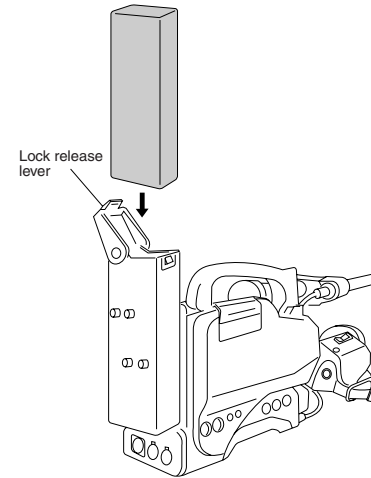

Be sure to set the POWER switch to OFF before replacing the battery pack.

4. POWER SUPPLY

4-2 Battery Pack Operation (Cont'd)

Using an Anton-Bauer Battery Pack

To use an Anton-Bauer battery pack (Propack 13/14, Trimpack 13/14, Magnum 13/14, Compack 13/14 Series), it is necessary to detach the battery case from the GY-DV500 and replace it with the Anton-Bauer battery holder. Use the following battery holder.

- Battery holder: Anton-Bauer QRQ27

Detaching the Battery Case From the GY-DV500 and Attaching The Anton-Bauer Battery

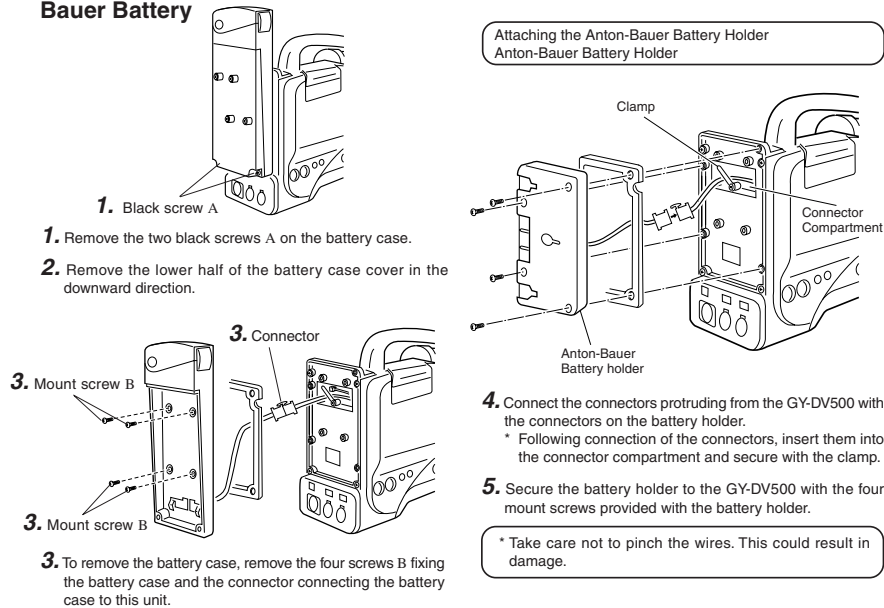

Attaching and Detaching an Anton-Bauer Battery Pack

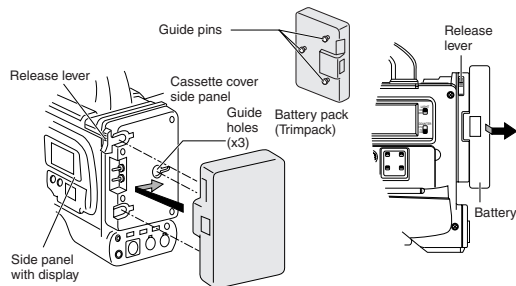

Attaching the Battery Pack

1. Align the 3 guide pins of the battery pack with the guide holes on the battery holder, and push straight to insert the battery pack.
The battery cannot be attached properly if the guide pins are not inserted straight.
2. Slide the battery pack toward the side panel where the cassette cover is located until it clicks.
Now the battery pack has been attached.

Detaching the Battery Pack

- While pushing and holding the release lever, slide the battery pack toward the side panel where the LCD display is located, then pull the battery pack outward to remove.

4. POWER SUPPLY

4-2 Battery Pack Operation (Cont'd)

REMAINING BATTERY POWER DISPLAY

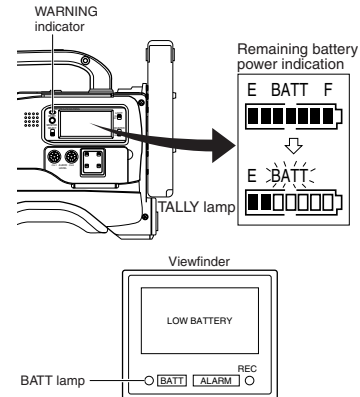

To display the remaining battery power accurately, set the VCR Setup Menu item No. 396 BATTERY TYPE according to the type of the battery pack in use.
* See page 69.

The status of the remaining battery power can be checked by the Remaining Battery Power Display.
* See page 22.

- When the remaining battery power is nearly exhausted, the following warning messages will appear. In this case, replace with a fully charged battery as soon as possible.
- Remaining battery power indication: Segment bar and "BATT" indicator start to blink
- WARNING indicator and TALLY lamp blink
- Viewfinder:
 - BATT lamp and TALLY lamp blink
 - "LOW BATTERY" character indication (Status 0 or Status 1 mode)
- Alarm sound beeps

After the remaining battery power warnings appear, the GY-DV500 automatically stops operation if the battery power operation is continued.

Operating Time with Battery Pack

When the VF-P115B is used as the viewfinder and a fully charged battery pack is attached, the approximate continuous operating time is as follows:

Battery Pack	Continuous Operating Time (at 25 °C)
NP-1B	60 minutes
Magnum 14	130 minutes
NP-L40	80 minutes

- Battery operating time may differ depending on the number of times the battery has been charged, charging conditions and the operating environment, etc. Use the values in the table on the left for approximate reference times.
- Operating time is reduced in areas with a cold environment.
- Operating time is reduced when the power zoom lens is used frequently.

PRECAUTIONS FOR THE BATTERY PACK

- When the battery pack is not in use, it must be stored in a cool, dry place.
Do not leave the battery pack in a place where it might be subject to a high temperature (under direct sunlight in a car, etc.), this could cause leakage of the fluid or shorten service life.
- When the terminal section of the battery pack gets dirty, the operating time will be shortened.
- If the operating time becomes greatly reduced even immediately after recharging, the service life of the battery pack is nearly finished. Purchase a new battery pack.

Recharging

- Recharge the battery pack after completely discharging it. Repeated recharging with residual charge remaining could result in reduced battery capacity.
- If the battery capacity is reduced by repeating incomplete recharging, or recharging without discharging, once discharge the battery pack completely, then recharge it to restore the battery capacity.
- If the battery pack is recharged with its internal temperature raised immediately after use, recharging may not be performed completely.

5. PREPARATIONS

5-1 Turning the Power ON

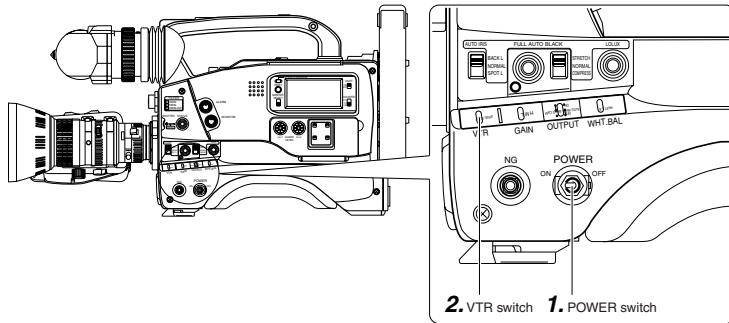

- Turn the POWER switch to ON.
 - The power is then supplied to the unit.
 - Video image is output to the viewfinder.
 - The display of the VCR section is turned on.
- Select the GY-DV500 operation mode with the VTR switch.
 - The GY-DV500 operation mode may differ when the power is turned ON and when the cassette is loaded depending on the setting of the VTR switch as follows:

VTR switch setting	GY-DV500 operation mode
SAVE	GY-DV500 enters the SAVE mode (tape protect mode) and stops the drum motor. "SAVE" is displayed in the VCR operation indicating section of the Status 1 mode screen in the viewfinder. In this mode, the tape is effectively protected. In this condition, press the VTR trigger button to start recording. However, it takes longer for the operation to take place from this condition than from the STBY mode.
STBY	When a recordable videocassette is loaded, the GY-DV500 enters the record-pause mode automatically. (The drum motor is still rotating.) "STBY" is displayed on the Status 1 screen in the viewfinder. In this condition, pressing the VTR trigger button starts recording immediately.

CAUTION:

Wait at least 5 seconds before turning the power ON again once it has been turned OFF. When the power is turned OFF, the unit automatically enters the tape protect mode. It takes approximately 5 seconds to enter the tape protect mode. Do not turn the power ON again within this interval.

5. PREPARATIONS

5-2 Cassette Loading and Unloading

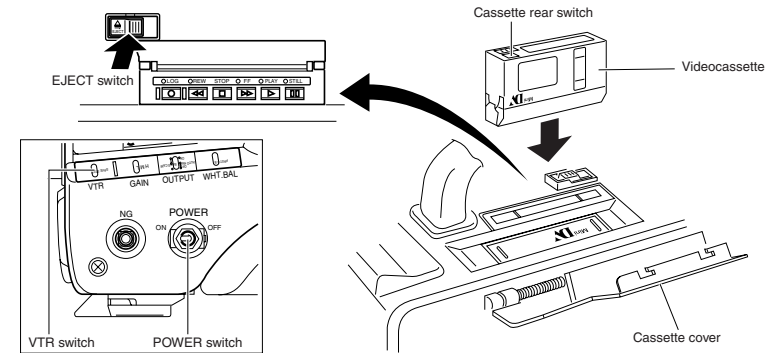

- A cassette cannot be loaded or unloaded while the GY-DV500 is in POWER OFF mode.
- Use a videocassette tape marked MiniDV.
- The videocassette should be held vertical and inserted straight into the slot.

Loading the Cassette

- Set the POWER switch to ON.
 - Slide the EJECT switch to the side to open the cassette cover.
 - Insert a videocassette into the cassette slot after removing the tape slack. Ensure that the videocassette is fully inserted.



The cassette indicator on the display blinks during tape loading and lights steadily after the loading has been completed.
 - Slowly close the cassette cover by pushing it in all the way. When the cassette cover is closed, the OPERATE LED lights up green and the unit is in the condition where it can be operated. In the SAVE mode, the OPERATE LED lights orange.
- The condition at the completion of loading varies depending on the position of the VTR switch and the switch on the back of the videocassette as shown below.

VTR switch	Switch on Back of Videocassette	
	REC	SAVE
STBY	Enters record-pause mode after back-spacing.	The unit enters stop mode. "REC INH" is displayed for a few seconds on the counter display.
SAVE	In the record-pause mode and the drum rotation is stopped.	

* Recording can be started by pressing the VTR trigger button from the record-pause condition. For details, see page 50 "Basic Record-ing Operation".

After the cassette cover is closed, it takes about 8 seconds before the unit can start recording or before it enters the stop mode.

CAUTION:

The GY-DV500 cannot be operated while the cassette cover is open. Make sure to close the cover before operating the unit.

Unloading the Cassette

- Set the POWER switch to ON.
- Slide the EJECT switch all the way to the side to start tape ejection.



The cassette indicator on the display blinks during tape ejection and turns off after the ejection has been completed.

 - It takes a few seconds before the cassette is ejected after the EJECT switch is moved.
- Take out the videocassette.
- Close the cassette cover.

CAUTION:

Do not leave the unit for a long period with the cassette cover open as dirt or other foreign objects may enter the VCR section and cause malfunction.

5. PREPARATIONS

5-3 Setting the Date and Time

The date and time of the built-in clock should be set. During shooting, the date and time data are recorded in the sub-time code area on the tape.
During playback, the data are shown on the counter display. Powered by the backup lithium battery, the set date and time data continue to count even when the power is switched off.

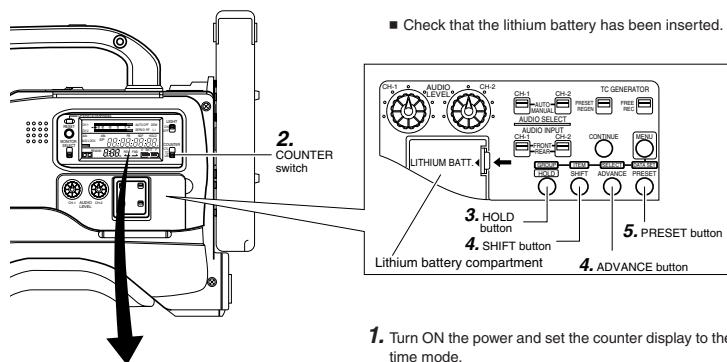

■ Check that the lithium battery has been inserted.

1. Turn ON the power and set the counter display to the date/time mode.
 - Set the VCR Setup Menu item No. 516 DISPLAY SELECT to "CLOCK".
 - See "Displaying and Setting VCR Setup Menus" on page 67.
 - See "VCR Setup Menu" on page 69.
2. Set the COUNTER switch to TC or UB.
 - To set the time: Set the switch to TC.
The time (Hour, Min., Sec.) is indicated on the counter display. (24-hour clock system)
 - To set the date: Set the switch to UB.
The date (Month, Day, Year) is indicated on the counter display.
3. Press the HOLD button to enter the setting mode.
The "HOLD" indicator lights up on the display to indicate that the unit is in the setting mode.
The leftmost digit on the counter blinks.
4. Set the date and time.
 - Each time the ADVANCE button is pressed, the value of the blinking digit increases.
 - Each time the SHIFT button is pressed, the digit to the right of the currently blinking one starts blinking. When pressed while the rightmost digit is blinking, the leftmost digit starts blinking again.
Repeat the above procedure to set the value of all the digits.
5. To decide the set date and time data, press the PRESET button.
The "HOLD" indicator on the display turns off and the date/time display stops blinking.
The time starts counting.

Memo:

To display and set the time code or user's bit, set the VCR Setup Menu item No. 516 DISPLAY SELECT to "TC".

Time display (COUNTER switch: TC)

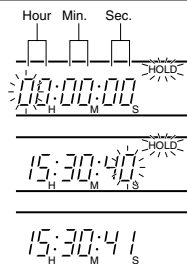

Date display (COUNTER switch: UB)

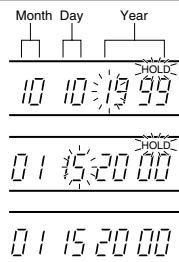

6. SETTING AND ADJUSTMENTS BEFORE SHOOTING

6-1 Camera Settings

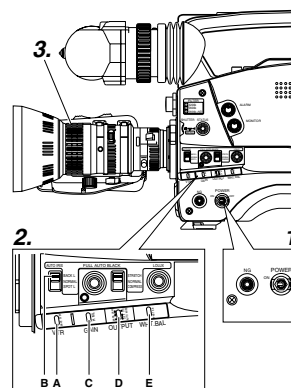

1. POWER ON

- ① First place a charged battery pack in the battery case on the rear section of the unit. If battery pack is not used, connect DC power to the DC INPUT connector on the rear section of the unit using the AC power adapter (AA-P250) to supply DC 12 V current.
- ② Set the POWER switch on the unit to ON.

2. SWITCH positions

- A. Set the VTR switch to STBY.
- B. AUTO IRIS switch; set to NORMAL.
- C. GAIN switch; set to L. The L position is 0 dB.
- D. OUTPUT switch; set to CAM/AUTO KNEE OFF.
- E. WH.T. BAL (Auto White Balance) switch; set to A or B.

3. Set the lens' iris mode switch to "A" (AUTO IRIS side)

4. Choose the proper color temperature conversion filter.

	FILTER	Suitable Location
1	3200K	Indoors, dark outdoors
2	5600K	Outdoors
3	5600K+ND	Outdoors under clear sky

5. Using the SHUTTER dial, set the shutter speed to OFF.

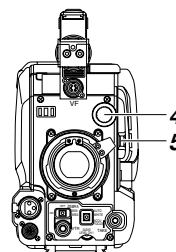

6. SETTING AND ADJUSTMENTS BEFORE SHOOTING

6-2 Viewfinder Adjustment

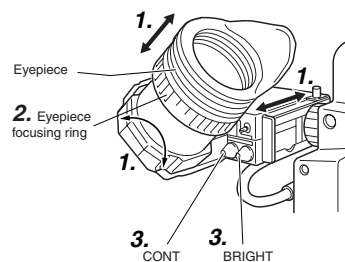

1. Adjust the position and angle of the viewfinder.

2. Diopter adjustment

Rotate the eyepiece focusing ring until the viewfinder screen image is clearly visible.

3. Brightness and contrast adjustment

When the ambient brightness changes, etc., the brightness and contrast of the viewfinder screen can be adjusted with the BRIGHT and CONT controls.

6-3 External Monitor Adjustment

Display the camera built-in color bar signal on the video monitor and adjust the colors, contrast and brightness.

1. Connect a color video monitor to the MONITOR OUT connector of the GY-DV500.

2. Set the OUTPUT switch to BARS to output the color bar signal (SMTPE type color bars).

3. Set the monitor's BLUE CHECK function to ON so that the screen turns entirely blue.

4. Adjust the CHROMA control of the monitor so that there is no difference in brightness between the color bars ① and ⑧, ⑦ and ⑭.

5. With the BLUE CHECK function ON, adjust the PHASE control of the monitor so that there is no difference in brightness between the color bars ③ and ⑩, ⑤ and ⑫.

6. If the phase control adjustment above causes a difference in brightness between the color bars ① and ⑧, ⑦ and ⑭, start again from the CHROMA control adjustment in step 4.

7. Set the monitor's BLUE CHECK function to OFF to switch the monitor back to the standard screen (R, G and B will all appear).

8. Use the monitor's brightness control to adjust so that the color bars ⑬ and ⑮ disappear but ⑱ is visible.

1. Connect a colour video monitor to the MONITOR OUT connector of the GY-DV500.

2. Set the OUTPUT switch to BARS to output the colour bar signal (EBU type colour bars).

3. Set the monitor's BLUE CHECK function to ON so that the screen turns entirely blue.

4. Adjust the CHROMA control of the monitor so that there is no difference in brightness between the colour bars ① and ⑦.

5. With the BLUE CHECK function ON, adjust the PHASE control of the monitor so that there is no difference in brightness between the colour bars ③ and ⑤.

6. If the phase control adjustment above causes a difference in brightness between the colour bars ① and ⑦, start again from the CHROMA control adjustment in step 4.

7. Set the monitor's BLUE CHECK function to OFF to switch the monitor back to the standard screen (R, G and B will all appear).

■ SMTPE type color bars

White	Yellow	Cyan	Green	Magenta	Red	Blue
①	②	③	④	⑤	⑥	⑦
Blue	Black	Magenta	Black	Cyan	Black	White
⑧	⑨	⑩	⑪	⑫	⑬	⑭
Black	White	Black				
⑮	⑯	⑰			⑱	⑲
						⑳
						㉑

■ EBU type colour bars

White	Yellow	Cyan	Green	Magenta	Red	Blue	Black
①	②	③	④	⑤	⑥	⑦	⑧

The colour bar screen has a configuration as shown above. The description hereinafter refers to the positions in the colour bar screen using the numbers.

6. SETTING AND ADJUSTMENTS BEFORE SHOOTING

6-4 Back Focus Adjustment

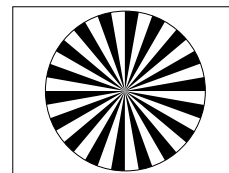
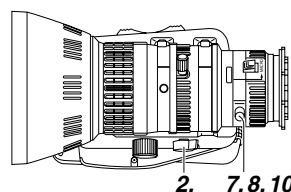
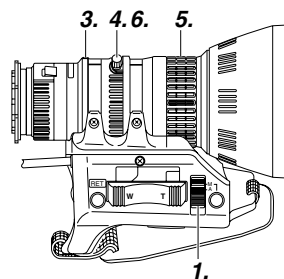

Siemens star chart

It is only necessary to perform this when the lens is attached for the first time or when focusing is not correct in both the telephoto and wide-angle positions. Adjust the viewfinder for sharpness first.

It is easier to adjust back focus when the subject is more than 3 meters from the camera. The optimal subject for this adjustment is a Siemens star chart.

1. Set the IRIS mode switch to M (Manual).

2. Set the zoom mode to MANU (Manual).

3. Open the iris ring. If the illumination is too strong, reduce it or move to a darker place.

4. Turn the zoom lever until the lens is at the maximum telephoto position.

5. Bring the subject into focus.

6. Set the lens to maximum wide-angle.

7. Loosen the back focus ring retaining knob.

8. View the same subject and adjust the back focus ring for the best possible focus.

9. Repeat steps 4. through 8. about three times for fine adjustment until the subject remains in focus in both the telephoto position and the wide-angle position.

10. Tighten the back focus ring retaining knob to secure the ring.

Memo:

ACCU FOCUS can also be used in the above step 3.

6. SETTING AND ADJUSTMENTS BEFORE SHOOTING

6-5 White Balance Adjustment

Since the color of light (color temperature) varies depending on the light source, it is necessary to re-adjust the white balance when the main light source illuminating the subject changes.

Note:

When a subject illuminated by a halogen lamp with a color temperature of 3,200K is shot while the color temperature conversion filter setting is set to 5,600K, a proper white balance adjustment and (FAW) Full Time Auto White balance may not be accomplishable. In this case, change the color temperature conversion filter setting to 3,200K and then carry out the white balance adjustment and (FAW) again.

- Do not adjust using any highly reflective objects, such as metal, etc., as this may result in improper white balance adjustment.

WHITE BALANCE ADJUSTMENT

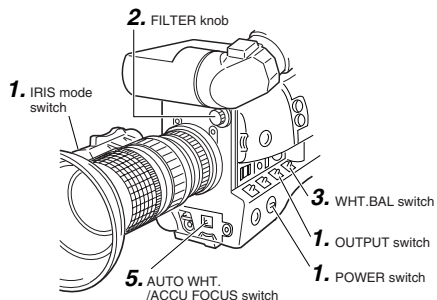

Two kinds of white balance adjustment results can be stored in memories AUTO1 and AUTO2.

Adjustment procedure

- Set the following switches.
 - Set the POWER switch to ON.
 - Set the OUTPUT switch to CAM-AUTO KNEE OFF.
 - Set the IRIS mode switch of the lens to A (Auto).
- Set the FILTER knob according to the current lighting.
- Set the WHT.BAL switch to A or B.
- Place a white object near the centre of the screen under the same lighting conditions as the target subject and zoom in to fill the screen with white.
- Tilt the AUTO WHT./ACCU FOCUS switch upward (to AUTO WHITE) once and release it. "AUTO WHITE A, B OPERATION" is displayed in the viewfinder while the auto white balance adjustment circuit operates. "AUTO WHITE A, B OK" is displayed when the white balance has been adjusted properly.

Error messages

• NG: OBJECT (Improper object)

Displayed when there is not enough white color on an object or the color temperature is not suitable. Replace the color temperature conversion filter or use another white object and re-adjust the white balance.

• ERROR: LOW LIGHT (Insufficient illumination)

Displayed when the illumination is dim. Increase the illumination and then re-adjust the white balance.

• ERROR: OVER LIGHT (Excessive illumination)

Displayed when the light is excessively bright. Decrease the illumination and then re-adjust the white balance.

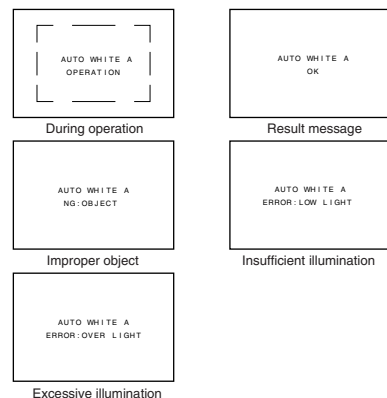

FULL-TIME AUTO WHITE BALANCE (FAW)

The FAW function adjusts the white balance value automatically as the lighting condition changes.

This mode is convenient when you have no time to adjust the white balance or when the camera is moved frequently in and out of places under different lighting conditions.

Setting procedure

The FAW function can be activated with item "FAW" on the OPERATION MENU.

This item allows allocation of the FAW function to one of the WHT.BAL switch positions, A, B or PRESET.

☞ See "OPERATION Screen" on page 73.

6. SETTING AND ADJUSTMENTS BEFORE SHOOTING

6-6 Switch Settings of the VCR Section

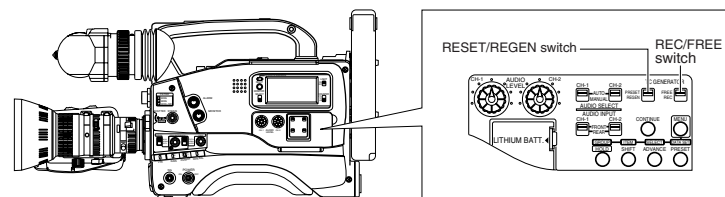

Audio input signal selection

Use the AUDIO INPUT switch to select whether the sound recorded on audio channel 1 or 2 is the sound from the microphone connector on the front section or the sound from the AUDIO INPUT connector on the rear section.

☞ See page 47.

Audio recording level adjustment selection

Select "AUTO" or "MANUAL" for the recording level adjustment mode for each audio channel.

☞ See page 48.

VCR Setup Menu setting

• REMOTE SELECT

Confirm that "LOCAL" is selected if you want to operate on the GY-DV500 only.

• BACK TALLY MODE

Select the lightning pattern of the BACK TALLY lamp.

• INPUT SELECT (U-ver. only)

Select the input video signal. To record the GY-DV500's signal, set to "CAMERA". ☞ See page 68.

• LOW CUT IN

For each audio input connector, select whether or not the lower frequency components of the audio signal are cut. Set to this position to eliminate the wind noise of the microphone.

• SAMPLING RATE

Select the sampling rate for audio recording (48 kHz or 32 kHz).

• FRONT VOLUME ENABLE

Set whether or not the front section's audio volume control should be used. The front section's audio volume control only affects the CH1 audio channel.

• LONG PAUSE TIME

Select the time (in minutes) until the GY-DV500 enters the tape protection mode (drum rotation stops) when the record-pause mode is continued for long time.

• SSF MODE

Select the mode of the S.S.F. (Super Scene Finder) function. S.S.F. function: Stores the time code of desired scenes or cue points in the unit's memory.

☞ See "How to Use the S.S.F. Function" on page 60.

• DISPLAY SELECT

Select the counter display (time code or date/time indication) when the COUNTER switch is set to "TC" or "UB".

Setting the time code recording function

The GY-DV500 records SMPTE-standard time code for U-ver. or EBU-standard time code for E-ver. during recording. Set the switches according to applications.

- To record a time code as set in the built-in time code generator:

- Set the PRESET/REGEN switch to PRESET.
- Set the REC/FREE switch.

If it is required to record continual time codes across different scenes, set the switch to REC.

- VCR Setup Menu setting (U-ver. only)
Select the time code generator's framing mode as drop frame or non-drop using the VCR Setup Menu item No. 416 "NON DROP/DROP".

- To record a time code in continuation of the existing time code on the tape:

- Set the PRESET/REGEN switch to REGEN.

For details on the time code operations including time code presetting, see "TIME CODE OPERATION" on page 56.

6. SETTING AND ADJUSTMENTS BEFORE SHOOTING

6-7 Audio Input Signal Selection

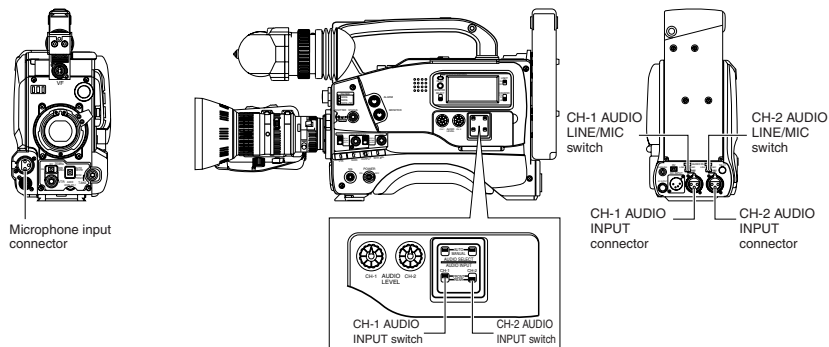

The GY-DV500 is provided with the microphone connector on the front section and the two AUDIO INPUT connectors at the rear section for audio input.

On the other hand, two channels of sound can be recorded on the tape in digital PCM format.

Using the AUDIO INPUT switch, select for each channel (CH1 and CH2) whether the sound to be recorded should be the sound from the microphone connector on the front section or the sound from the AUDIO INPUT connectors on the rear section.

■ Selecting the CH-1 channel input sound

Make the selection using the CH-1 AUDIO INPUT switch.

FRONT : The sound from the microphone connector on the front section is recorded on the CH-1 channel.

REAR : The sound from the CH-1 AUDIO INPUT connector on the rear section is recorded on the CH-1 channel.

■ Selecting the CH-2 channel input sound

Make the selection using the CH-2 AUDIO INPUT switch.

FRONT : The sound from the microphone connector on the front section is recorded on the CH-2 channel.

REAR : The sound from the CH-2 AUDIO INPUT connector on the rear section is recorded on the CH-2 channel.

■ Selecting the front section's microphone connector

A microphone (phantom microphone, etc.) requiring +48 V power supply or other type of camera microphone (monaural) can be connected.

- In accordance with the connected microphone, specify the phantom microphone or other type of microphone using the Camera Setup Menu item CAM MIC +48V.
- The reference input level is -60 dBs.

■ Selection of rear audio input connectors

Select the audio signal input to the AUDIO INPUT connector using the [LINE/MIC] switch. Make settings for the CH-1 and CH-2 AUDIO IN connectors separately.

LINE : Set to this position when connected to audio equipment, etc.

The reference input level is +4 dBs.

MIC : Set to this position when using a monaural microphone.

The reference input level is -60 dBs.

MIC +48 V : Set to this position when a microphone (phantom microphone) requiring +48 V DC power supply is connected.

CAUTION:

When connecting a component that does not require +48 V power supply, make sure that the LINE/MIC switch is not set to MIC +48V.

When using the microphone on the front section, set the Camera SETUP screen item "CAM MIC +48V" to "OFF". Neglecting this could cause damage to the connected component. ⁶³ See page 77.

6. SETTING AND ADJUSTMENTS BEFORE SHOOTING

6-8 Recording Level Adjustment

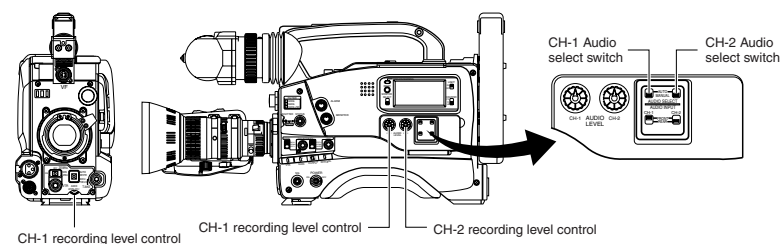

For each audio channel, use the AUDIO SELECT switches to select whether the recording level adjustment should be set to AUTO mode or MANUAL mode.

- When set to AUTO: Recording level is fixed. In this mode, the recording level control does not function.
- When set to MANUAL: Recording level can be adjusted using the recording level controls for each audio input.

■ Adjusting the recording level control of the front section

The recording level control on the front section only affects the CH-1 channel sound.

To use the recording level control on the front section, make the following settings.

- Set the CH-1 AUDIO SELECT switch to MANUAL.
- Set the VCR Setup Menu item No. 246 FRONT VOLUME ENABLE to "ENABLE".

CAUTION:

The recording level controls on the side section work regardless of the setting of the VCR Setup Menu item No. 246 FRONT VOLUME ENABLE. ⁶³ See page 68.

Manual Adjustment of Recording Level

The recording level can be adjusted manually when the GY-DV500 is in the record, record-pause or stop mode.

1. Set the AUDIO SELECT switch of the channel whose recording level that you want to adjust manually to MANUAL.

2. Rotate the recording level control corresponding to the audio input to be adjusted.

- Adjust so that the peak level does not exceed the -3dB point when a loud sound is input.
- With microphone input, since the limiter circuit is activated, the recording level will not exceed 0 dB even if the recording level control is turned up.

■ How to use the recording level control on the front section

- 1 Set the recording level control on the front section to maximum (10) position.
- 2 Initially, adjust the recording level using the CH1 recording level control on the side.
- 3 When a loud sound is input during recording, use the recording level control on the front section to lower the recording level.

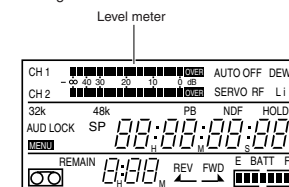

Viewfinder Status 1 Mode

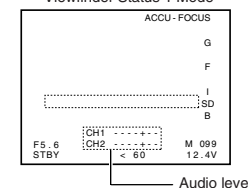

Indicator level (reference)

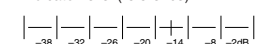

CAUTION:

When the AUDIO INPUT LINE/MIC switch on the rear section is set to MIC, be sure to check that the microphone is connected to the AUDIO INPUT connector. If the microphone is not connected, increasing the recording level could cause noise from the input connector to be recorded on the tape. When the microphone is not connected to the AUDIO INPUT connector on the rear panel, set the LINE/MIC switch to LINE or turn down the recording level control.

6. SETTING AND ADJUSTMENTS BEFORE SHOOTING

6-9 Monitoring Audio during Recording

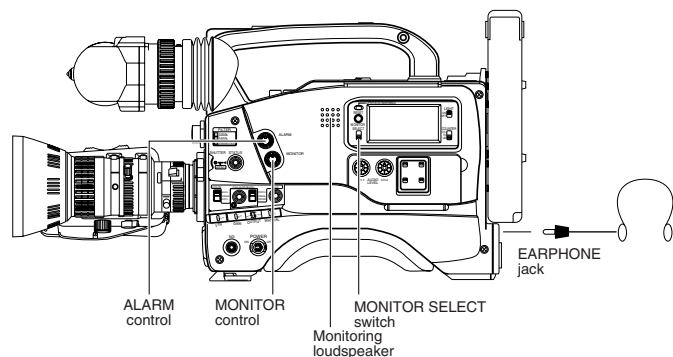

The audio input during recording, in record-pause or stop mode can be monitored through the monitoring loudspeaker or earphone.

- The monitoring audio is not output from the loudspeaker while the EARPHONE jack is in use.
- Select the audio channel to be monitored using the MONITOR SELECT switch.
 - CH-1** : The sound input to the CH-1 channel is output.
 - MIX** : The sound input to the CH1 and CH2 channels is output mixed.
 - CH-2** : The sound input to the CH-2 channel is output.
- The MONITOR volume control adjusts the monitoring volume.
- The loudspeaker or earphone outputs an alarm tone in the case of an abnormal condition occurring in the unit. An alarm tone is also output when the tape end is reached or when the battery is running down. The alarm tone volume can be adjusted with the ALARM control. For details on the alarm tone, see page 87.

* Do not increase the audio monitoring volume excessively; otherwise howling with the camera microphone may occur.

7. SHOOTING OPERATION

7-1 Basic Recording Operation

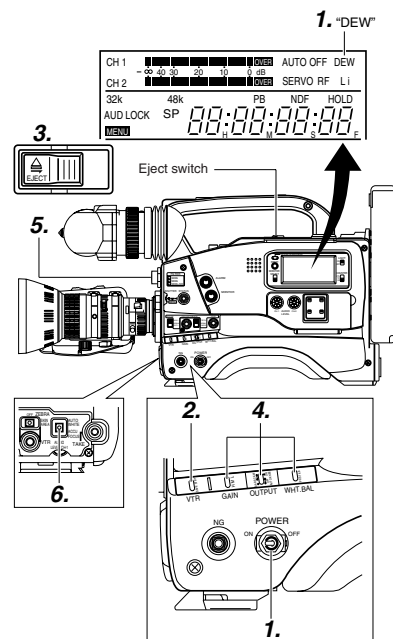

1. Set the POWER switch to ON.

Power is supplied to the unit. Check that the condensation indicator "DEW" does not appear on the display. If it is lit, wait until the indicator goes out.

2. Set the VTR switch to the STBY position.

Even when the VTR switch is set to the "SAVE" position, pressing the VTR trigger button will start recording. However, in this case, it is necessary to wait a short time until the recording actually starts. For details on the VCR SAVE mode, see page 52.

3. Slide the EJECT switch to open the cassette cover.

- Ensure that the switch on the back of the videocassette is set to REC and insert the cassette correctly. When the cassette is inserted, the tape is loaded and the unit enters the record-pause mode.
- Slowly close the cassette cover.

- Use a videocassette marked MiniDV.
- If the cassette cover is not closed, the GY-DV500 will remain inoperative.
- At the loading time and power switch set to on time, the built-in head cleaner will emit a sound while operating. This does not indicate a malfunction.
- After the cassette cover is closed, it takes about 8 seconds before the unit is ready for recording.

4. Set the switches as required.

- **GAIN** : Sensitivity suitable for the subject
- **OUTPUT** : "CAM/AUTO KNEE ON"
- **WHT-BAL** : "A" or "B"
- Set the IRIS switch of the lens to "A".

5. Select the FILTER according to the lighting condition.

- Position 1 (3200K) : For shooting indoors or outdoors when illumination is not sufficient
- Position 2 (5600K) : For shooting outdoors
- Position 3 (5600K + ND): For shooting outdoors under a clear sky.

6. Adjust the white balance.

☞ See "White Balance Adjustment" on page 45.

7. Point the camera at the subject and determine the angle of view and focus with the zoom lever and the focusing ring.

7. SHOOTING OPERATION

7-1 Basic Recording Operation (Cont'd)

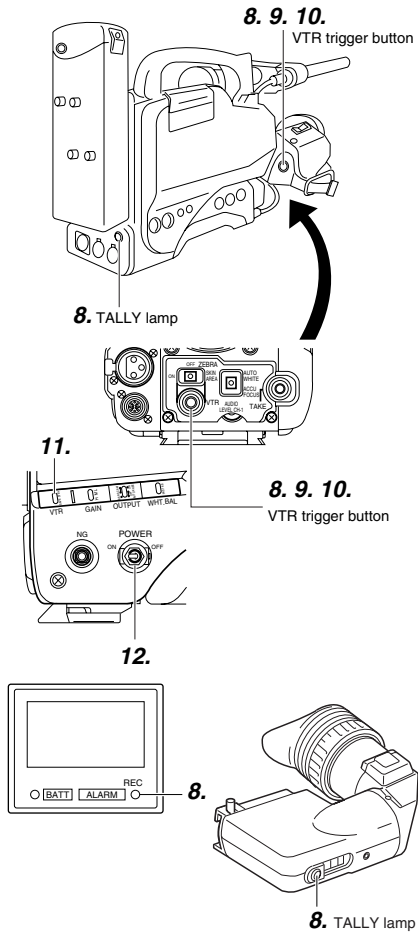

8. Press the VTR trigger button on the GY-DV500 or lens to start recording.
Once recording has started, the BACK TALLY lamp on the rear section of the unit and the tally lamp on the viewfinder light red, and the REC indication in the viewfinder lights green.

Note:

- The lighting conditions of the BACK TALLY lamp on the rear section of the unit can be changed by setting the VCR Setup Menu item No. 082 BACK TALLY MODE.
- The lamp in the viewfinder and on the front section will blink from when the button is pressed and until recording actually starts. ☞ See page 68.

9. To stop recording, press the VTR trigger button again. The TALLY lamp and REC indicator lamp go out and the unit enters the record-pause mode.
When the VTR trigger button is pressed, the unit enters the record-pause mode after rewinding the tape for about 2 seconds (back-spacing).

10. To restart recording:
Press the VTR trigger button on the GY-DV500 or lens.

11. Ending recording:
Enter record-pause mode and perform the following operations as required.

- When it is required to unload the videocassette:
 - Slide the EJECT switch.
- When it is required to put the unit in save mode:
 - Set the VTR switch to SAVE.
 Drum rotation stops and the GY-DV500 enters the tape protection/power-saving mode.

12. When shooting is completely finished, eject the cassette and set the POWER switch to "OFF".
When the unit is not going to be used for a long period, detach the battery pack.

About the QUICK REC Mode

If the VTR trigger button is pressed immediately after the videocassette is inserted, the mode becomes the QUICK REC mode that enables quick start of recording.
However, when shooting starts in the middle of the tape, a blank space appears as the new scene will not be linked smoothly with the previous image.
Also, the time code does not continue. (Some overlap may also occur.)

Note:

- The unit enters stop mode at tape-end automatically, and if kept longer than 3 or 30 minutes in this mode, SAVE mode is maintained. ☞ See "Menu No. 307: LONG PAUSE TIME" on page 69.
- If the VTR trigger button is pushed very quickly and repeatedly, or the POWER switch is moved immediately after being pressed, the viewfinder REC indicator lamp may blink and the GY-DV500 may not enter the record mode. To remedy this condition set the POWER switch to OFF and wait for 5 seconds or more before turning the power on again.
- A neat transition to the next recorded scene cannot be guaranteed if you end a recording by turning the POWER switch or DC power supply OFF, or by removing the battery pack.
- Before recording a scene that is particularly important, perform test shooting to ensure that normal recording is possible.
- The power consumption can be reduced by setting the LIGHT switch on the display and TALLY lamp to OFF.
- The microphone may pick up the sound of the lens' iris if the iris is changed abruptly or the iris is manually moved abruptly during recording. If you find the noise annoying, please purchase an optional microphone in order to move the microphone away from the lens or ensure that the iris is not changed abruptly during shooting.

For servicing

The QUICK REC mode of this unit is different from conventional models such as (GY-X1, GY-X2, and GY-X2B). It is not a fully automatic mode operation. In this case it is a function that shortens the time to the initiation of the start of the recording.

51

7. SHOOTING OPERATION

7-2 VCR Save Mode

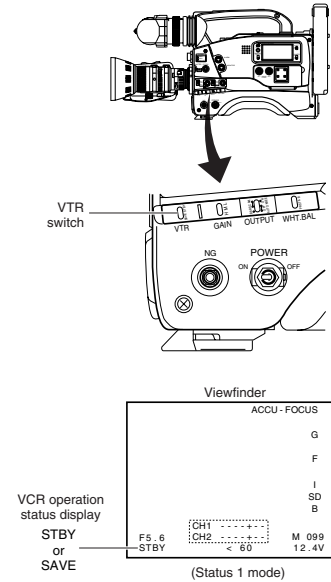

When a recordable videocassette is loaded, the GY-DV500 enters the record-pause mode. However, the record-pause operation condition differs depending on the setting of the VTR switch.

• VTR switch setting

- STBY : The GY-DV500 enters the record-pause mode, and the drum is rotating at this time. (Standby mode)
The "STBY" indicator appears in the VCR operation status display in the viewfinder (in Status 1 mode).
- In this condition, recording starts immediately when the VTR trigger button is pressed.
- SAVE : The GY-DV500 enters the record-pause mode but the drum is not rotating. (Save mode).
The tape is protected.
The "SAVE" indicator appears in the viewfinder (in Status 1 mode).
The OPERATE indicator lights orange. The display backlight turns off.

Note:

When the VCR Setup Menu item No. 396 SSF MODE is set to the CUE MODE or MARK mode, the VCR save mode is not entered.

Recording from the Save mode

- In the save mode, pressing the VTR trigger button will start recording.
However, in this case, it takes several seconds before the GY-DV500 starts recording.
- Pressing the VTR trigger button again interrupts the recording and the GY-DV500 enters the save mode again.

7-3 If Unit is Left in Record-Pause (Standby) Mode

When the GY-DV500 has remained in record-pause (standby) mode for about 30 minutes, the unit enters the save mode, in which the drum rotation is stopped automatically and the tape tension is released. (Save mode)

- To start recording from the save mode, press the VTR trigger button; the drum starts to rotate and recording starts in about 3 seconds.
- To return to the record-pause mode from the save mode, press the VTR trigger button TWICE; the drum starts to rotate.

- The time until the unit enters the save mode after it is placed in record-pause mode can be set to 3 minutes or 30 minutes with the VCR Setup Menu item No. 307 LONG PAUSE TIME.
When used in a cold environment, the setting will be 3 minutes regardless of the setting on the VCR Setup Menu.
☞ See page 69.

52

For servicing
See the service manual page 2-7 "2.4.3 Cleaning".

7. SHOOTING OPERATION

7-4 Checking Recorded Contents in Record-Pause Mode (Recording Check Function)

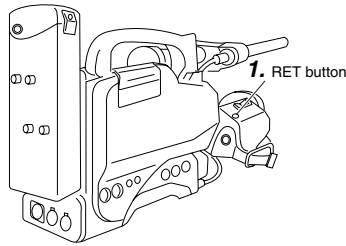

The recording check function is only valid in the standby mode (VTR switch set to STBY). In the record-pause mode, approximately 2 seconds of the last recorded portion can be played back.

- The recorded contents can be checked in the viewfinder or on a monitor connected to the MONITOR OUT or Y/C OUT connectors.
- In the viewfinder or on the monitor connected to the MONITOR OUT or Y/C OUT connectors, the video image from the VCR section is output.

1. In the record-pause mode, press the RET button on the camera lens section.
 - The tape is slightly rewound and played back for approximately 2 seconds.
 After playback is finished, the tape returns to the position at which the RET button is pressed and the record-pause mode resumes.

- When the RET button is kept pressed, the tape is rewound and played back for approximately 10 seconds at maximum.
- While the RET button is pressed, the record-mode is not entered even if the VTR trigger button is pressed.

- * This function does not work when the GY-DV500 is in the save mode or stop mode.
- * During recording check, the following indications will appear if the error rate increases due to head clogging, etc.
 - "RF" appears on the display panel.
 - "HEAD CLOG" appears on the counter display.
 - "VTR WARNING (HEAD)" appears in the viewfinder.

See the instructions page 8 "Head Cleaning".

8. PLAYBACK MODE

8-1 Playback Procedure

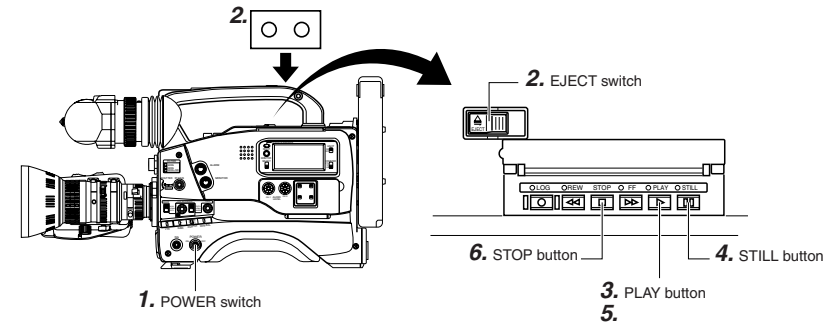

Operation

1. Set the POWER switch to ON.
2. Load the recorded videocassette correctly.
 - Slide the EJECT switch to the side. When the cassette cover opens, insert the videocassette and then close the cassette cover again.
 - When a recordable videocassette (with the switch on the back of the cassette set to REC) is loaded, the unit enters the record-pause mode (STBY mode). In this case, press the STOP button to release the record-pause mode.
3. Press the PLAY button.
 - ➔ The PLAY indicator lights and playback starts.
4. Press the STILL button to stop playback temporarily.
 - ➔ The STILL indicator lights and the unit enters the still mode.
5. To re-start playback, press the PLAY button.
 - ➔ The STILL indicator goes out and playback starts again.
6. To stop playback, press the STOP button.
 - ➔ The PLAY indicator goes out and the unit enters the stop mode.

CAUTION:

- When the still picture mode or stop mode has continued for about 30 minutes, the unit automatically switches to the save mode to protect the tape. The time until the tape protect mode is initiated can be set to 3 or 30 minutes with the VCR Setup Menu item No. 307 LONG PAUSE TIME. When used in a cold environment, the setting will be 3 minutes regardless of the setting on the VCR Setup Menu.
- Noise may appear in the picture during still mode. This does not indicate a malfunction.
- When the automatic tracking function is activated at the start of the playback mode, digital noise may appear on the playback image. This does not indicate a malfunction.
- This unit does not allow manual tracking adjustment.
- When playing back a tape recorded on another unit, digital noise may appear during playback. This does not indicate a malfunction.
- Following the loading, the built-in head cleaner will emit a sound while operating. This does not indicate a malfunction.

8. PLAYBACK MODE

8-2 Fast-Forward, Rewind

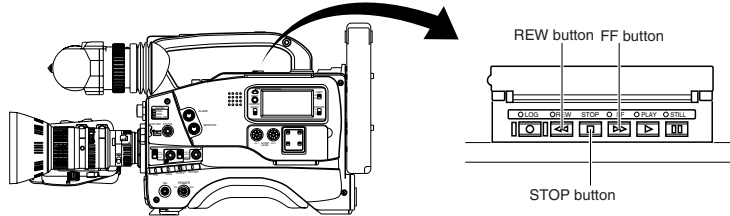

- Press the FF button in stop mode to fast forward the tape. Press the REW button in stop mode to rewind the tape.
- Press the STOP button to stop fast forwarding or rewinding.

- When the tape approaches the end during fast forwarding or rewinding, the tape speed decelerates to protect the tape.
- The time required for fast forwarding and rewinding may become longer when used in a cold environment. This is not a malfunction.

8-3 Search

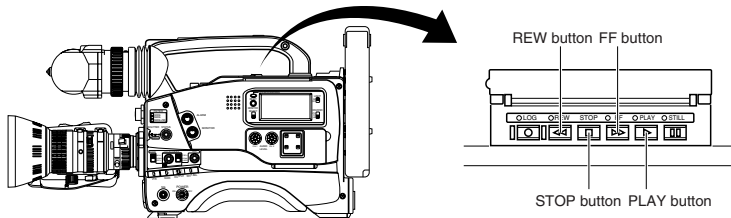

- Press the FF button in play mode to search the tape in the forward direction at about 10 times the normal speed.
- Press the REW button in play mode to search the tape in the reverse direction at about 10 times the normal speed.
- Press the PLAY button to resume normal playback.
- Press the STOP button to stop.

- The audio is reproduced during the search.
- Video noise may be observed or the image may become unstable during the search, but this is not a malfunction.

9. TIME CODE OPERATION

The GY-DV500 records SMPTE-standard time codes for U-ver. or EBU-standard time codes for E-ver. and user's bits. In the play or the record mode, the reproduced time codes or user's bits are shown on the counter display.

• Time code data cannot be output through the unit's connectors.

9-1 Displaying Time Code

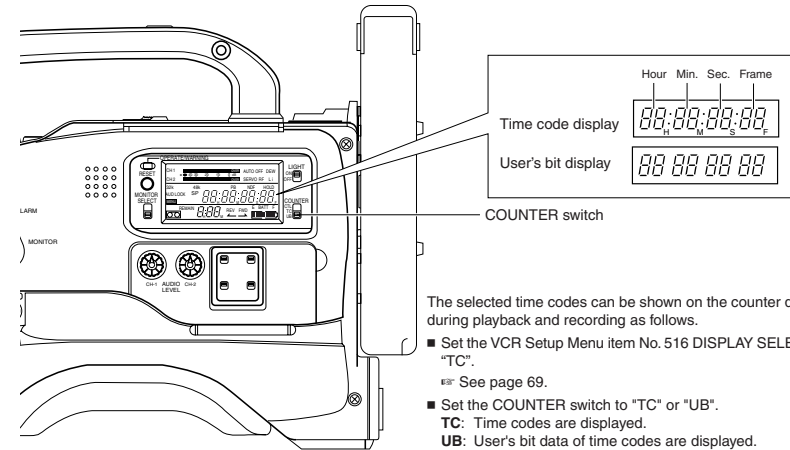

The selected time codes can be shown on the counter display during playback and recording as follows.

- Set the VCR Setup Menu item No. 516 DISPLAY SELECT to "TC".
- See page 69.
- Set the COUNTER switch to "TC" or "UB".
- TC:** Time codes are displayed.
- UB:** User's bit data of time codes are displayed.

9-2 Presetting and Recording of Time Code

The time code or user's bit data to be recorded onto the tape can be preset to a desired value.

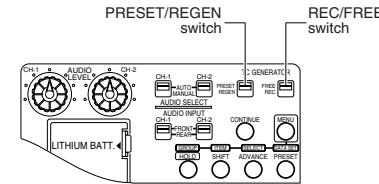

■ Setting the time code related switches

- Set the PRESET/REGEN switch to "PRESET".
- Set the REC/FREE switch.
- REC :** The data preset in the time code generator runs only during recording. Use this setting if it is required to record continual time codes across different scenes.
 - * However, approximately ± 1 -frame variations may occur in scene transition accuracy.
- FREE :** The time code starts to run from the time it is preset in the time code generator.

■ Setting the VCR Setup Menu (U-ver only)

- Set the VCR Setup Menu item No. 516 DISPLAY SELECT to "TC".
- Select the time code generator's framing mode using the VCR Setup Menu item No. 416 NON DROP/DROP.
- DROP :** The time code generator's running method is set to the drop frame mode. Use this setting when placing emphasis on the recording time. The "DF" indicator lights up on the display in the drop-frame mode.
- NON DROP :** The time code generator's running method is set to the non drop frame mode. Use this setting when placing emphasis on the number of frames.

In the NON DROP frame mode, the "NDF" indicator lights on the display.



U-ver. only

Drop frame/Non-drop frame mode
In the NTSC system, the actual number of frames per 1 second is approximately 29.97 frames, but the number of frames that becomes the processing reference of the time code is 30 frames. To compensate for this difference, the mode called drop mode drops frame 00 and 01 for every minute that cannot be divided by 10. The non-drop frame mode is when no frames are dropped and the actual time shift is neglected.

Note:

When the VCR Setup Menu item No. 398 SSF MODE is set to CUE MODE or MARK MODE, the time code generator's running method is internally set to the REGEN mode. If No. 398 SSF MODE is not set to OFF, the time code cannot be preset.

9. TIME CODE OPERATION

TIME CODE PRESETTING PROCEDURE (for U-ver.)

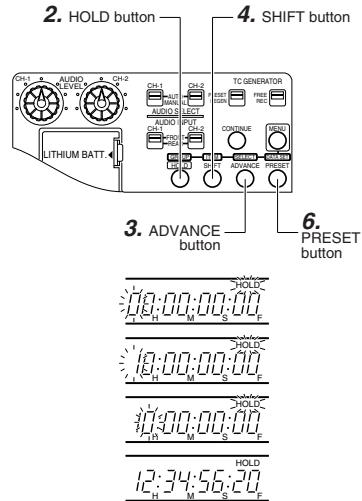

1. Display the time code on the counter display. Set the COUNTER switch to "TC".
 - Time code up to 23 hrs. 59 min. 59 sec. 29 frames can be preset.
 2. Place the time code generator in preset mode. Press the HOLD button.
 - The "HOLD" indicator lights on the display to indicate the preset mode. The first digit of the counter display blinks.
 3. Set the value of the blinking digit. Press the ADVANCE button.
 - The value of the blinking digit changes.
 4. Change the blinking digit. Press the SHIFT button.
 - The blinking digit changes.
 5. Set the desired value for all digits. Repeat steps 3. and 4. for each digit.
 6. Preset the set data in the memory. Press the PRESET button.
 - The set data is saved as the time code generator value. Following the above operation, the "HOLD" indicator disappears from the display, the counter stops blinking and the time code is preset.
 - If the REC/FREE switch is set to FREE, the time code starts to run.
- If you preset a wrong time code, perform steps 2. 3. 4. 5. and 6. again.

TIME CODE PRESETTING PROCEDURE (for E-ver.)

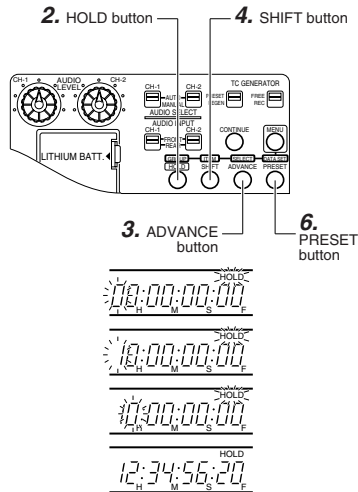

1. Display the time code on the counter display. Set the COUNTER switch to "TC".
 - Time code up to 23 hrs. 59 min. 59 sec. 24 frames can be preset.
 2. Place the time code generator in preset mode. Press the HOLD button.
 - The "HOLD" indicator lights on the display to indicate the preset mode. The first digit of the counter display blinks.
 3. Set the value of the blinking digit. Press the ADVANCE button.
 - The value of the blinking digit changes.
 4. Change the blinking digit. Press the SHIFT button.
 - The blinking digit changes.
 5. Set the desired value for all digits. Repeat steps 3. and 4. for each digit.
 6. Preset the set data in the memory. Press the PRESET button.
 - The set data is saved as the time code generator value. Following the above operation, the "HOLD" indicator disappears from the display, the counter stops blinking and the time code is preset.
 - If the REC/FREE switch is set to FREE, the time code starts to run.
- If you preset a wrong time code, perform steps 2. 3. 4. 5. and 6. again.

9. TIME CODE OPERATION

PRESETTING USER'S BIT DATA

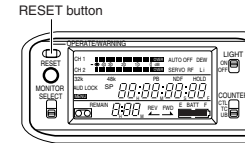

- Pressing the RESET button in the preset mode resets the time code or user's bit data to 00 00 00 00.
- If you press the HOLD button by mistake, press the HOLD button once more to return to the previous display.

- Display user's bit data on the counter display and perform the same procedure as the time code presetting procedure.
 - The user's bit can be specified using numerals or alphabetic letters from 0 to F for each digit.

Note:

Do not specify F in the user's bit data. Specification of F results in a special setting and reading of user's bit data during playback may become impossible. If all user's bit digits are set to F, the data cannot be read.

9-3 Recording Time Codes in Continuation of Time Codes Recorded on Tape

The GY-DV500 also incorporates a time code reader. Therefore, when the unit enters record mode from record-pause mode, it can read the time code data recorded on the tape and record time codes in continuation of the existing data. The recorded user's bit data is identical to the user's bit data recorded on tape.

* However, approximately ± 1 -frame variations may occur in scene transition accuracy. To enable this, set the time code related switches as follows before starting recording.

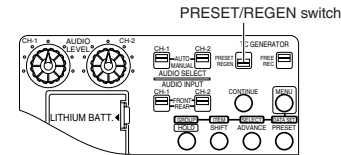

Setting

- Set the VCR Setup Menu item No. 516 DISPLAY SELECT to "TC".
 - See page 69.
- Set the counter display to show time codes or user's bit data.
- Set the PRESET/REGEN switch to REGEN.
 - The time code run mode becomes unrelated to the REC/FREE switch settings.
 - The time code framing mode automatically becomes the mode (drop frame or non drop frame) already recorded on the tape.

9. TIME CODE OPERATION

9-4 Reproducing Time Codes

The GY-DV500 incorporates a time code reader. During playback, the time code or user's bit data recorded on the tape is displayed on the counter display.

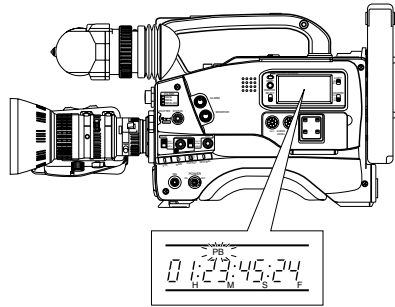

- Set the VCR Setup Menu item No. 516 DISPLAY SELECT to "TC".
 - ☞ See page 69.
- Set the counter display to indicate time code or user's bit data.
- Reproducing time codes
 - Press the PLAY button.
 - The "PB" indicator lights up on the display and the time code or user's bit data are indicated.

- When passing sections where the time code does not continue during playback, the time code stops running. The playback mode continues.

Note:

When a tape containing more than two hours of recorded time codes is played back on DV video equipment for normal consumer use, the time code may not be played back correctly.

10. S.S.F. (Super Scene Finder) FUNCTION

10-1 Explanation of the S.S.F. Function

During recording, the SSF function records the time code data at the point of time of a desired recorded scene in the unit's memory. Using the S.S.F. data stored in memory during after-processing of the recorded image allows efficient use of the tape. The S.S.F. function comprises the two modes CUE and MARK. Select the mode using the VCR Setup Menu item No. 398 S.S.F. MODE.

When the VCR Setup Menu item No. 398 SSF MODE is set to CUE MODE or MARK MODE, the time code generator's running method is internally set to the REGEN mode.

When shooting in either of the modes, the time code data is stored in the unit's memory when the TAKE button on the front section is pressed.

■ CUE Mode:

When the TAKE button is pressed at the desired scene during shooting of a given cut, the time code data at that point is stored as CUE data in the unit's memory.

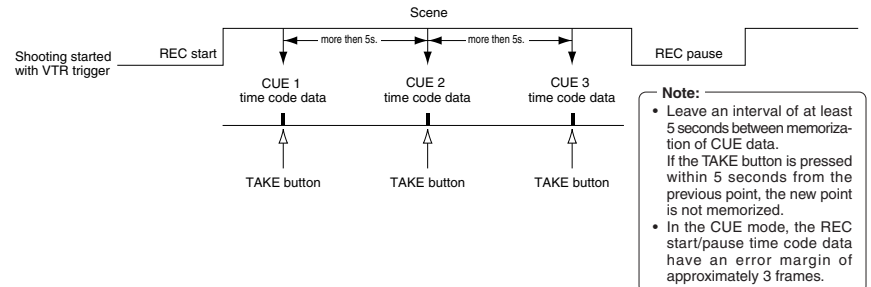

■ MARK MODE

During shooting of a given cut, press the TAKE button at beginning of a desired scene and then press the TAKE button again at the ending of the scene.

The time code data at the point where the TAKE button is pressed first becomes the start point of the scene and time code data at the point where the TAKE button is pressed the second time becomes the ending point, and both are stored in the unit's memory.

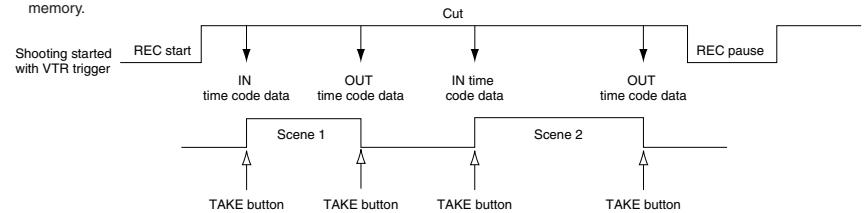

- In the MARK mode up to 119 scenes can be stored in memory. When the memory becomes full, the indication showing the number of recorded scenes on the viewfinder screen becomes "M: - -". However, if mixed with the CUE mode, the maximum number of scenes that can be stored decreases for each scene.
- In the CUE mode up to 237 points can be stored in memory. However, for each REC start/stop the maximum number of points that can be stored decreases by two points for each scene. The same is true when the CUE mode is mixed with the MARK mode.
- When the videocassette is replaced, new S.S.F. data is generated. S.S.F. data for six videocassettes can be stored in the internal memory.

Note:

- Be sure to record S.S.F. data continuously on the same tape. It is not possible to rewind the tape for overwriting during the recording. If the tape is rewound in the middle of a recording, or after similar operation is performed, be sure to use the Scene End Cue Up function in order to ensure that new data are recorded in continuation of the existing data.
 - ☞ See page 63.
- In the S.S.F. mode, the VTR save mode is not activated.

10. S.S.F. (Super Scene Finder) FUNCTION

10-2 How to Use the S.S.F. Function

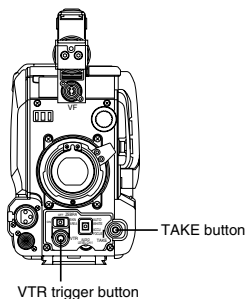

CUE Mode

- Set the S.S.F. mode as CUE mode.
Set the VCR Setup Menu item No. 398 S.S.F. MODE to "CUE".
* See page 69.
 - The CUE mode is indicated in the lower part of the Status 1 screen in the viewfinder.

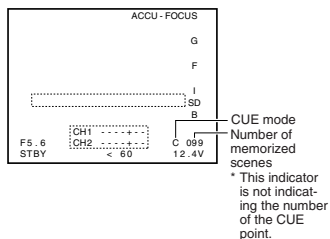

- Press the VTR trigger button to start the recording.
- When you reach the point that you want to memorize as the CUE point, press the TAKE button.
 - The time code data of the point where the TAKE button is pressed is stored in the unit's memory as CUE data. The LOG button's LED lights during memorization of the CUE point and the "e" mark is shown in the viewfinder.
 - Press the TAKE button each time you reach a point that you want to memorize as CUE data.
- Stop the recording.
Press the VTR trigger button.

Note:

- Once the S.S.F. data has been written to a videocassette, it is not possible to record S.S.F. data to the tape again.
- Once a tape with recorded S.S.F. data is rewound but not ejected before playback or recording is performed on it again, the previous S.S.F. data cannot be automatically erased when S.S.F. data are recorded (when you overwrite the previous image). Therefore, the S.S.F. data of the overlapped sections will not correspond to the video image. Furthermore, please note that the time code data may differ from the actual data if recording is started in the CUE mode in this situation.

10. S.S.F. (Super Scene Finder) FUNCTION

10-3 Deleting S.S.F. Data

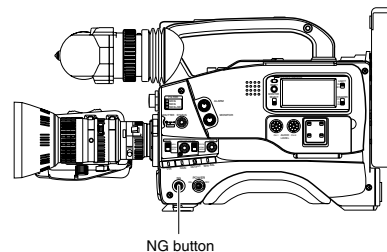

The S.S.F. data recorded in the unit's memory can be deleted in the record mode and the record-pause mode. This function is only valid in the MARK mode.

- In the record mode, press the NG button after the IN point has been stored or after the scene has been stored.
 - The S.S.F. data of the cut that you are currently shooting is deleted.
 - When the NG button is pressed after the IN point has been stored, the scene number is not updated.
 - The S.S.F. data of previous cuts are not deleted.
- In the record-pause mode, press the NG button.
At the point when the TAKE button is used to store the next scene, the S.S.F. data of the immediately preceding cut is deleted.

Note:

The NG button is only valid for the immediately preceding scene. The erase of scene data by the NG button cannot be confirmed on the unit.

10-4 Resetting S.S.F. Data

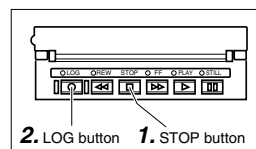

- LOG button
- STOP button

Operation

- Press the STOP button to enter the stop mode.
- Press the RESET button while the LOG button is kept pressed.
 - All the S.S.F. data held in the memory are erased. However, the reel number is not cleared.

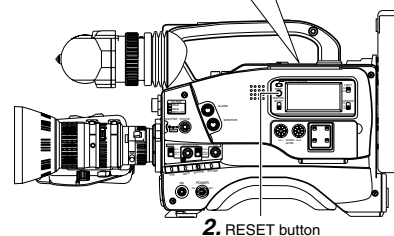

- RESET button

Note:

The unit is not provided with a function for reading out the S.S.F. data from a tape. Necessary data should be moved to another device before resetting. Also, to read out the S.S.F. data from a tape, please use the optional DV Videocassette Recorder BR-DV600.

10. S.S.F. (Super Scene Finder) FUNCTION

10-5 Writing S.S.F. Data to Tape

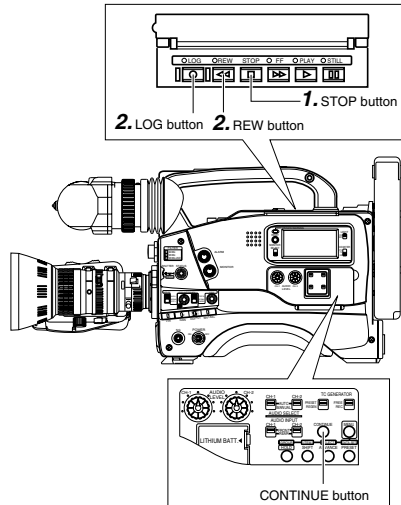

S.S.F. data stored in the unit's memory can be written to the beginning of tape.

Operation

1. Press the STOP button to enter the stop mode.
 - The REW indicator blinks during tape transport in the writing position.
 - The LOG indicator lights while S.S.F. data are being written to the tape.
 - When writing to the tape is completed, the LOG indicator goes out.
2. Press the REW button while the LOG button is kept pressed.

About the Scene End Cue Up Function

- When the CONTINUE button is pressed while the LOG button is kept pressed in the stop mode, the tape winds to the S.S.F. data's last OUT point, after which the unit enters the record-pause mode. (Scene End Cue Up) The FF button's LED blinks during the Scene End Cue Up mode.

Note:

Once a tape with recorded S.S.F. data is ejected and then reinserted again, the previous data will be erased if new S.S.F. data are recorded on the tape.

10-6 Outputting S.S.F. Data

The S.S.F. data stored in the unit's memory can be output by RS-232C control via the VTR REMOTE connector.

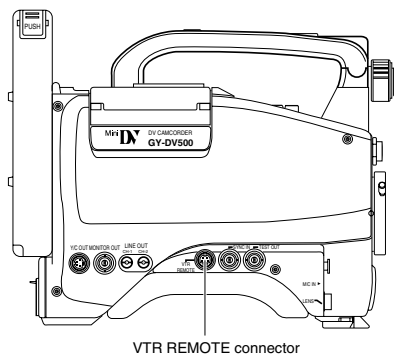

11. USING EXTERNAL COMPONENTS

11-1 Connecting a Video Component with DV Connector

Rear section of GY-DV500

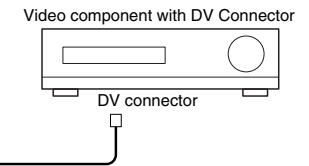
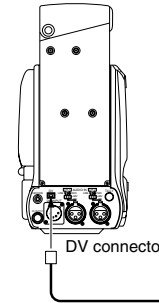

DV cable

Connection

Connect the DV connector on the GY-DV500 to the DV connector on the video component using the DV cable.

Settings

- Recording the image of the video component with DV connector on the GY-DV500
- To input the image via the DV connector, set the VCR Setup Menu item No. 126 INPUT SELECT to "IEEE1394".
 - * Settings cannot be changed during recording.
 - ☞ See page 68.

- Recording the playback image or audio of the GY-DV500 on the video component with DV connector
- To remote control the playback operation of the GY-DV500 from the video component with DV connector, set the VCR Setup Menu item No. 050 REMOTE SELECT to "IEEE1394".
 - ☞ See page 68.

U-ver. only

11. USING EXTERNAL COMPONENTS

11-2 Connecting a PC

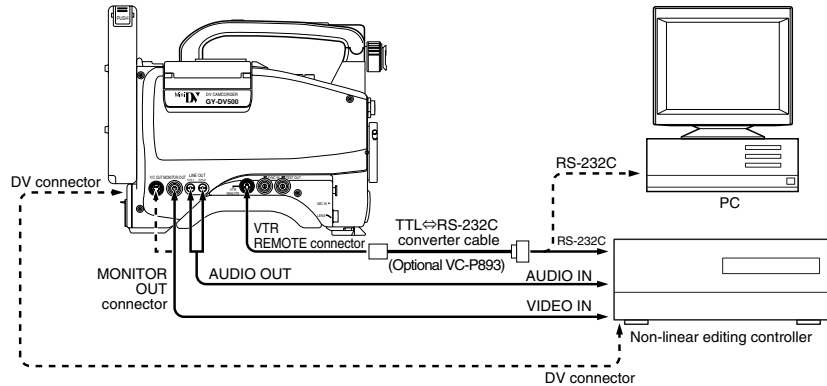

Connections

Connect the GY-DV500's VTR REMOTE connector to the RS-232C connector on the PC or the non-linear editing controller using the TTL ↔ RS-232C converter cable.

Or connect the GY-DV500's DV connector and the DV connector of the non-linear editing controller using a DV cable. For compatible non-linear editing controller, consult with your JVC dealer.

Settings

- To remote control the PC or non-linear editing controller by means of RS-232C, set the VCR Setup Menu item No. 050 REMOTE SELECT to "RS232C". ☞ See page 68.
- To remote control the GY-DV500's VCR using the DV connector's IEEE1394 option, set the VCR Setup Menu item No. 050 REMOTE SELECT to "IEEE1394". ☞ See page 68.

Note:

- When a cable is connected to the VTR REMOTE connector, the VTR Setup Menu is not displayed in the viewfinder. Make settings on the VTR Setup Menu while the cable is not connected.
- When a cable is connected to the VTR REMOTE connector, the VCR operation mode will not be displayed correctly on the Status1 screen in the viewfinder.

■ The S.S.F. data stored in the unit's memory is output from the VTR REMOTE connector.

12. SETUP MENU

12-1 VCR Setup Menu

The setup menus for the VCR section can be set while observing the menu in the viewfinder and on the unit's counter display. The set contents are stored in the memory and retained even after the power is switched OFF.

VCR SETUP MENU CONFIGURATION

The VCR Setup Menu is a two-layer construction.

The VCR Setup Menu consists of seven group menus divided according to functions. When a Group menu is selected, the menu's Item menu opens. Each Item menu contains one or several items, and the various items can be set individually as required.

VCR Setup Menu

Group Name	Item Menu Contents
000 SERVO/SYSTEM	Selection of remote control to control the unit Selection of BACK TALLY lamp lighting pattern
100 VIDEO (U-ver. only)	Selection of video input
200 AUDIO	Selection of low cut for audio input signals Selection of sampling frequency for audio input signals Selection of front section audio volume control
300 SYSTEM	Selection of long pause/still duration Selection of battery type Selection of S.S.F. (Super Scene Finder) mode
400 TIME CODE (U-ver. only)	Selection of time code framing mode
500 ON SCREEN	Selection of counter display method (Time code/Date/Time)
HM HOUR METER	Display of hour meter (accumulated running time of head drum)

U-ver.

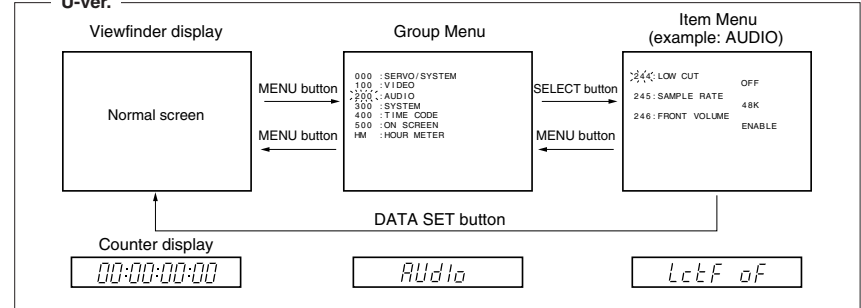

E-ver.

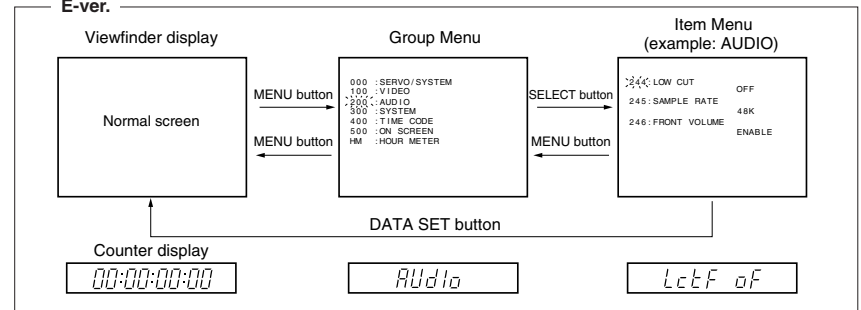

12. SETUP MENU

12-1 VCR Setup Menu (Cont'd)

DISPLAYING AND SETTING VCR SETUP MENUS

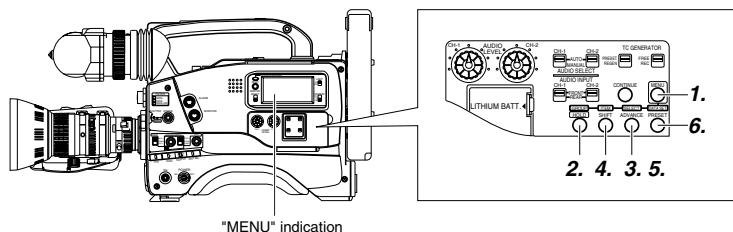

MENU indication

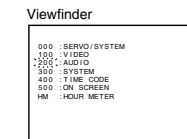

GROUP menu screen for U-ver.

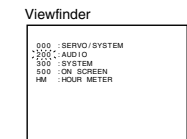

GROUP menu screen for E-ver.

Counter display

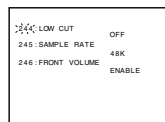
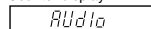

Item menu screen

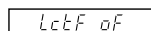

DATA SET display

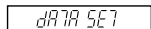

1. Engaging the VCR Setup Menu mode.

Press the MENU button.

- The "MENU" indication in the display section starts blinking and the VCR Setup Menu appears in the viewfinder and on the counter display.

Note:

When a cable is connected to the VTR REMOTE connector, the VTR Setup Menu is not displayed in the viewfinder.

2. Selecting the GROUP.

Press the GROUP button.

- Each time the GROUP button is pressed the selected GROUP number is shown blinking on the viewfinder screen. The counter display shows the selected group.

3. Open the Item menu of the selected GROUP.

Press the SELECT button.

- Each time the ITEM button is pressed the selected item number is shown blinking on the viewfinder screen. The counter display shows the selected item.

5. Changing the setting value of the item.

Press the SELECT button and select the setting value.

- When multiple items should be set, repeat the operations of steps 4. and 5.
- To set menu items in other groups, press the MENU button. When the relevant group menu is displayed, perform the setting.
- When the GROUP button is pressed, the items of the higher order group menu are displayed.

6. Saving the setting value.

Press the DATA SET button.

- "DATA SET" appears in the viewfinder and on the counter display and the setting value is saved in the GY-DV500's memory. The display returns to the normal screen mode when data has been saved.
- If the MENU button is pressed without pressing the DATA SET button, the display returns to the normal screen mode without the setting value being changed.

12. SETUP MENU

12-1 VCR Setup Menu (Cont'd)

VCR SETUP MENU CONTENTS

Group	Item	Setting Value	Contents	Factory Setting
SERVO /SYSTEM	050: REMOTE SELECT	LOCAL IEEE1394 RS232C	Selection of the method for remote control of the VCR. LOCAL : Choose this setting when the VCR should be controlled using the operation buttons on the GY-DV500 only. IEEE1394 : Choose this setting when the VCR should be remote controlled from a DV connector equipped video component connected to the DV connector on the rear section of the GY-DV500. RS232C : Choose this setting for control by means of the VCR remote control signal from the VTR REMOTE connector on the GY-DV500. * The operation buttons on the GY-DV500 remain effective even when set to IEEE1394 or RS232C.	LOCAL
	rnSL	Lc IE 23		
	082: BACK TALLY MODE	OFF ON BLINK	Selection of the lighting pattern of the BACK TALLY lamp on the rear section during recording. OFF : The lamp is always off. ON : The lamp lights during recording. It remains off until the VTR trigger button is pressed to start the recording. BLINK : The lamp lights during recording. It blinks when the VTR trigger button is pressed to start the recording.	BLINK
VIDEO (U-ver. only)	126: INPUT SELECT	CAMERA IEEE1394	Selection of the input video signal. Settings cannot be changed during recording. CAMERA : Camera image is input. IEEE1394 : The image from the DV connector equipped video component connected to the DV connector on the rear section is input.	CAMERA
	vid	cA IEEE1394		
AUDIO	244: LOW CUT	OFF CH1 CH2 CH1 & CH2	To select whether or not the low frequencies of the audio signal from the audio input connectors are cut. Set to ON to reduce the wind noise of the microphone. OFF : The CH1 and CH2 low frequencies are not cut. CH1 : Only the low frequencies of the audio signal input to the CH1 channel are cut. CH2 : Only the low frequencies of the audio signal input to the CH2 channel are cut. CH1 & CH2 : The low frequencies are cut for both CH1 and CH2.	OFF
	LctF	oF 01 02 on		
	245: SAMPLING RATE	32K 48K	To select the sampling rate for digital PCM audio recording. 32K : Digital recording occurs with 12-bit, 32 kHz sampling 48K : Digital recording occurs with 16-bit 48 kHz sampling. * The DV format offers recording tracks for up to 4 channel when recording using 12-bit, 32 kHz sampling. The GY-DV500 records two of these tracks. The GY-DV500 does not allow after-recording.	48K
246: FRONT VOLUME ENABLE	snPL	32 48		
	246: FRONT VOLUME ENABLE	DISABLE ENABLE	To select whether or not the front section recording level control should be operative. The front section recording level control only affects the audio signal recorded on CH1. DISABLE : Use of the front section recording level control is disabled. ENABLE : Use of the front section recording level control is enabled. * The CH-1 recording level control on the side section works regardless of the setting.	ENABLE
	FruL	oF on		

12. SETUP MENU

12-1 VCR Setup Menu (Cont'd)

Group	Item	Setting Value	Contents	Factory Setting
SYSTEM	307: LONG PAUSE TIME	3MIN 30MIN	To select the time (minutes) before the save mode (drum head rotation stopped) is engaged when the record-pause, still or stop condition continues. 3MIN : 3 minutes 30MIN : 30 minutes * When used in a cold environment, the setting will be 3 minutes regardless of the setting.	30MIN
	LGpT	03 30		
	396: BATTERY TYPE	12V 13.2V 14.4V	To be set in accordance with the used battery back type. 12V : Choose this setting when using 12V battery (12V DC Flat Shape type). 13.2V : Choose this setting when using 13.2V battery (Anton-Bauer Trimpack 13, Propack 13, Magnum 13, Compack 13). 14.4V : Choose this setting when using 14.4V battery (Anton-Bauer Trimpack 14, Propack 14, Magnum 14, Compack 14).	12V
	bAtt	12 13 14	Note: • If this setting is neglected, the unit's display of remaining of battery power and generation of battery alarm will not work correctly. • This setting is valid when battery pack is used. It is invalid when a DC power supply is used.	
SYSTEM	398: SSF MODE	OFF CUE MODE MARK MODE	Selection of the S.S.F. (Super Scene Finder) mode. S.S.F. function: While recording, the time code data of a desired recorded scene is stored in the unit's memory when the TAKE button on the front section is pressed. Settings cannot be changed during recording. OFF : S.S.F. function is not available. CUE MODE : Selects the CUE mode. When the TAKE button is pressed, the time code data of the scene recorded at that point is stored in the memory. MARK MODE: Selects the MARK mode. When the TAKE button is pressed the first time, the time code of this point is stored as start point of the scene. When the TAKE button is pressed the second time, the time code of this point is stored as ending point of the scene. For details on the S.S.F. function, see page 60. • When the VCR Setup Menu item No. 398 S.S.F. MODE is set to CUE or MARK, the time code generator's running method is internally set to the REGEN mode.	OFF
	SSF	oF cU nr		
TIME CODE (U-ver. only)	416: NON DROP/DROP	DROP NON DROP	Selection of the time code generator's framing mode as either drop or non-drop mode. DROP : The internal time code generator runs in drop mode. Choose this setting when emphasizing the recorded time. NON DROP: The internal time code generator runs in non drop mode. Choose this setting when emphasizing the frame number.	DROP
	tcG	dF nF		
ON SCREEN	516: DISPLAY SELECT	TC CLOCK	Selection of the appearance of the counter display when the COUNTER switch is set to "TC" or "UB". TC : The time code is displayed. CLOCK: The date/time is displayed.	TC
	dSP	tc cL		

12. SETUP MENU

12-2 Camera Menu Screen Flow

Camera Menu Screen Flow

As illustrated below, the Camera Menu is a menu screen comprising several layers. The first layer of the CAMERA MENU screen is for choosing and setting the menus required in accordance with functions or purposes.

The unit also allows the contents of menu settings to be stored in three files (SCENE FILE A, B, OFF).

• SCENE FILE A, B By performing the FILE STORE operation on the FILE MANAGE screen, the contents of menu settings can be stored and retained in the unit. However, the SET UP menu contents are stored even if the FILE STORE operation is not performed.

Use SCENE FILE A or B to store and retain the contents of menu settings that remain more or less fixed.

• SCENE FILE OFF Whenever you want to change the menu settings, use this SCENE FILE. The menu setting contents are stored in the unit even if the FILE STORE operation is not performed.

When shooting, select the file with the menu settings to be used from among the three SCENE FILE files on the CAMERA MENU screen.

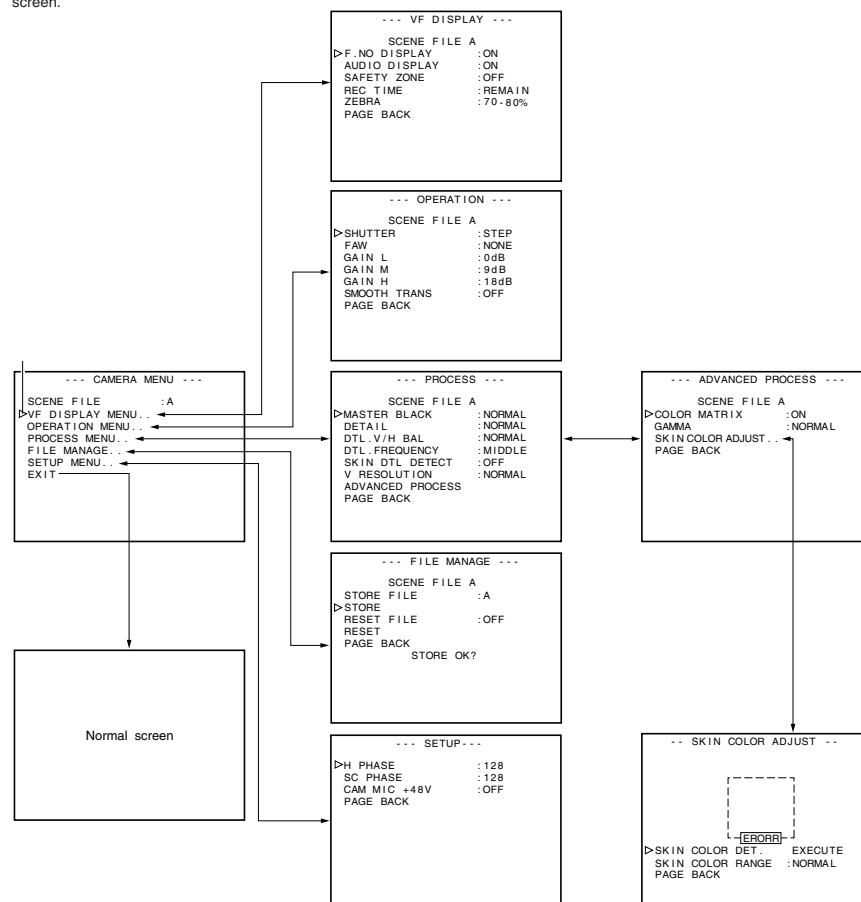

12. SETUP MENU

12-3 How to Select from the Camera Menu

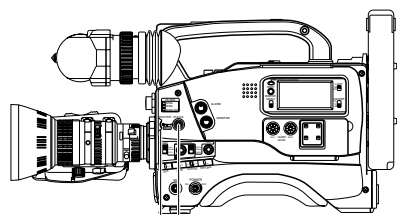

STATUS button
2. 3. 4. 5. 6. 8.
SHUTTER dial

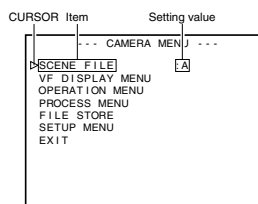
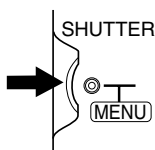

CAMERA MENU screen

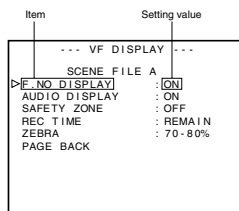

VF DISPLAY MENU screen

1. Press the STATUS button for 1 second to display the CAMERA MENU screen in the viewfinder.
2. Choose the file with the camera menu settings to be used. (SCENE FILE A, B or OFF)
 - ① Turn the SHUTTER dial up or down to align the cursor with SCENE FILE, and then press the SHUTTER dial in the direction of the arrow.
 - The area with the setting value starts blinking, and the value can now be changed.
 - ② Turn the SHUTTER dial up or down to select the setting value. (A, B or OFF)
 - ③ Press the SHUTTER dial in the direction of the arrow.
 - The setting value stops blinking but remains lit.
3. Turn the SHUTTER dial up or down to align the cursor with the menu item to be set, and then press the SHUTTER dial in the direction of the arrow.
 - The selected menu screen appears in the viewfinder.
4. Choose the menu item from the menu screen. Turn the SHUTTER dial up or down to align the cursor with the menu item to be set, and then press the SHUTTER dial in the direction of the arrow.
 - The area with the setting value starts blinking, and the value can now be changed.
5. Change the setting value. Turn the SHUTTER dial up or down to change the setting value, and then press the SHUTTER dial in the direction of the arrow.
 - The setting value stops blinking but remains lit.
 - To change multiple items, repeat steps 4. and 5. above.
6. Return to the CAMERA MENU screen. Turn the SHUTTER dial up or down to align the cursor with the PAGE BACK item, and then press the SHUTTER dial in the direction of the arrow.
 - To change the settings of other menu screens, perform the operations described in steps 3. to 6. above.
7. If SCENE FILE A or B is selected, choose the FILE MANAGE item from the CAMERA MENU screen and perform the operations for storing a file.
 - ☞ See "FILE MANAGE Screen" on page 76.
 - * It is not necessary to perform the file storage operations for changes made to the SETUP MENU.
8. Complete the CAMERA MENU setting. Turn the SHUTTER dial up or down to align the cursor with the EXIT item on the CAMERA MENU screen, and then press the SHUTTER dial in the direction of the arrow.
 - The normal screen returns in the viewfinder.

12. SETUP MENU

12-4 VF Display Screen

Item	Function, Operation	Variation Range	Initial Setting
F NO. DISPLAY	Selects whether or not the F-number of the lens iris is displayed on the Status 1 screen. ON F-number is displayed. OFF F-number is not displayed.	ON OFF	ON
AUDIO DISPLAY	Selects whether or not the audio indicator is displayed on the Status 1 screen. ON Audio indicator is displayed. OFF Audio indicator is not displayed.	ON OFF	ON
SAFETY ZONE	Selects the safety zone setting. ☞ See "Safety Zone" on page 29.	OFF ZONE 1 ZONE 2 ZONE 3	OFF
REC TIME	Sets whether the remaining tape recording time or TIME CODE is displayed on the Status 1 screen. TIME CODE TIME CODE is displayed. * The time code is displayed even if the VCR Setup Menu item No. 516 DISPLAY SELECT is set to "CLOCK". REMAIN Remaining time is displayed.	TIME CODE REMAIN	REMAIN
ZEBRA	Switches the luminance level of the subject sections where the zebra pattern is displayed. 70-80% Zebra pattern is displayed in sections with luminance levels between 70% and 80%. 85-95% Zebra pattern is displayed in sections with luminance levels between 85% and 90%. OVER 95% Zebra pattern is displayed in sections with luminance levels over 95%. OVER 100% Zebra pattern is displayed in sections with luminance levels over 100%.	70-80% 85-95% OVER95% OVER100%	70-80%
PAGE BACK	The CAMERA MENU returns when the SHUTTER dial is pressed with the cursor at this position.	-	-

12. SETUP MENU

12-5 OPERATION Screen

Item	Function, Operation	Variation Range	Initial Setting
SHUTTER	The SHUTTER button on the right side section is used to select STEP for fixed shutter speed or V.SCAN variable scanning rate for shooting computer monitor screens. STEP Enables setting of different fixed shutter speeds. [1/100, 1/250, 1/500, 1/1000, 1/2000] : U-ver. [1/120, 1/250, 1/500, 1/1000, 1/2000] : E-ver. VARIABLE Selected when shooting computer monitor screens, etc. [Variable range: 60.1 to 2084.6 Hz, 60.3 to 2084.6 Hz (V. MAX mode)] : U-ver. [Variable range: 50.1 to 2067.8 Hz, 50.3 to 2067.8 Hz (V. MAX mode)] : E-ver.	STEP VARIABLE	STEP
FAW	Selects the W.BAL switch (Ⓢ on page 13) position to which the FAW (Full-Time Auto White Balance Adjustment) function is to be assigned. NONE FAW function is not used. A FAW is assigned to the A position. B FAW is assigned to the B position. PRESET FAW is assigned to the PRESET position.	NONE A B PRESET	NONE
GAIN L GAIN M GAIN H	Selects the gain value in each position of the GAIN switch (Ⓢ on page 13).	-3dB 0dB 6dB 9dB 12dB 18dB ALC	L: 0dB M: 9dB H: 18dB
SMOOTH TRANS	Smoothens the transition when the GAIN switch (Ⓢ on page 13), or WHT.BAL switch (Ⓢ) is switched over and achieves gradual change in place of sudden change. However, the smooth transition function does not function when switching the GAIN switch set in ALC, FAS button and the LOLUX button. ON Activates the smooth transition function. OFF Deactivates the smooth transition function.	ON OFF	OFF
PAGE BACK	The CAMERA MENU returns when the SHUTTER dial is pressed with the cursor at this position.	-	-

12. SETUP MENU

12-6 PROCESS Screen

Item	Function, Operation	Variation Range	Initial Setting
MASTER BLACK	Adjusts the pedestal level (master black), which is the reference of black. • To increase the pedestal level Increase the number. (UP) • To decrease the pedestal level Decrease the number. (DOWN)	MAX (100) 99 201 gradations to NORMAL (0) to -99 MIN (-100)	NORMAL
DETAIL	Adjusts the detail enhancement level. • To sharpen details Increase the number. (UP) • To soften details Decrease the number. (DOWN)	MAX (9) 8 16 gradations to NORMAL (0) to -5 MIN (-6)	NORMAL
DTL. V/H BAL	Sets the direction, horizontal (H) or vertical (V), in which stronger detail enhancement is applied. To strengthen the H enhancement Increase the number (UP). To strengthen the V enhancement Decrease the number (DOWN). Note: While the LOLUX function is operating, the setting value is fixed at NORMAL and "FIX" is displayed.	H-MAX (4) 3 9 gradations to NORMAL (0) to -3 H-MIN (-4)	NORMAL
DTL. FREQUENCY	Varies the detail enhancement level by changing the detail enhancement frequency. Set in accordance with the subject HIGH Applies strong detail enhancement. Used to shoot subjects with fine patterns. MIDDLE Applies medium detail enhancement. LOW Applies weak detail enhancement. Used to shoot subjects with large patterns. Note: While the LOLUX function is operating, the setting value is fixed at MIDDLE and "FIX" is displayed.	HIGH MIDDLE LOW	MIDDLE
SKIN DTL DETECT	Sets the Skin Detail function to ON or OFF. ON Skin Detail function activated. OFF Skin Detail function not activated. ☞ See "Using the Skin Detail Function" on page 84.	ON OFF	OFF
V. RESOLUTION	Increases the vertical resolution. • NORMAL Vertical resolution 380 lines. • V.MAX Vertical resolution 450 lines Note: The sensitivity is degraded and the bright sections may be colored depending on the subject.	NORMAL V.MAX	NORMAL
ADVANCED PROCESS	ADVANCED PROCESS Displays the ADVANCED PROCESS Screen. ☞ See "ADVANCED PROCESS Screen" on page 75.		
PAGE BACK	The CAMERA MENU returns when the SHUTTER dial is pressed with the cursor at this position.	-	-

12. SETUP MENU

12-7 ADVANCED PROCESS Screen

Item	Function, Operation	Variation Range	Initial Setting
COLOR MATRIX	Sets the color matrix OFF..... Deactivates the color matrix function ON The color reproducibility is enhanced, but noise increases. CAUTION: During the LOLUX operation, COLOR MATRIX is fixed to the OFF setting and "FIX" is displayed.	ON OFF	ON
GAMMA	Correction of the gamma curve to decide the reproducibility of black color. • To enhance the black color reproducibility. However, halftones will be lost for white section Increase the number • When reproducibility of the black color is not so important Decrease the number CAUTION: • During LOLUX operation, "FIX" is displayed because GAMMA is fixed at the MIN value.	MAX (8) 7 17 gradations to NORMAL (0) to -7 MIN (-8)	NORMAL
SKIN COLOR ADJUST	Pressing the SHUTTER dial once when the cursor is at this position switches the screen to display the SKIN COLOR ADJUST screen.		
PAGE BACK	The PROCESS MENU returns when the SHUTTER dial is pressed with the cursor at this position.	-	-

12-8 SKIN COLOR ADJUST Screen

Item	Function, Operation	Variation Range	Initial Setting
SKIN COLOR DETECT	Sets whether it is possible to change the color used by the Skin Detail function. EXECUTE Choose this setting to allow detection of the color used by the Skin Detail function. STOP Choose this setting to stop detection of the color used by the Skin Detail function. ☞ See "Using the Skin Detail Function" on page 84.	STOP EXECUTE	STOP
SKIN COLOR RANGE	The setting of this item can only be changed when the SKIN COLOR DETECT item is set to EXECUTE. This setting is for adjusting the skin color range where Skin Detail functions. (When this item is selected, the area where the Skin Detail function is applicable is indicated by zebra patterns on the screen.) While viewing the zebra pattern range, perform the adjustment. Increasing the range Increase the number Decreasing the range Decrease the number	WIDE +19 (33 gradations) to NORMAL to -11 NARROW	NORMAL
PAGE BACK	The ADVANCED PROCESS MENU returns when the SHUTTER dial is pressed with the cursor at this position.	-	-

For servicing

See the service manual page 1-17 "1.12 CHANGING THE COLOR MATRIX SETTING".

75

12. SETUP MENU

12-9 FILE MANAGE Screen

The unit has three files that can be used for storing camera menus. The FILE MANAGE screen is for performing the operations for saving the set CAMERA MENU.

- When menu settings are made using SCENE FILE A or B, the contents of the settings will be invalid if the storage operations are not performed on this screen. However, the SETUP MENU settings will be valid even if the storage operations are not performed.
- When menu settings are made using SCENE FILE OFF, the contents are stored in the unit at the time settings are changed on each menu screen even if the storage operations are not performed.

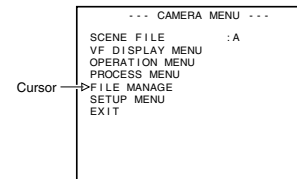
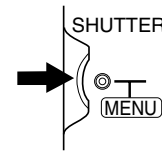
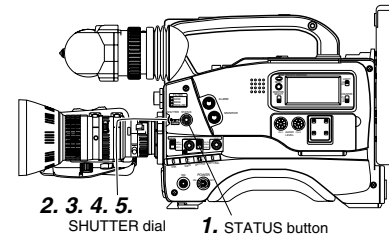

CAMERA MENU screen

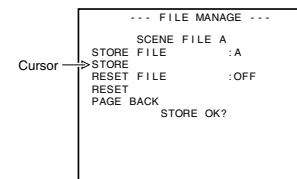

FILE MANAGE screen

Storage Operation

1. Press the STATUS button for about 1 second to display the CAMERA MENU screen.
2. Turn the SHUTTER dial to align the cursor with the FILE MANAGE item, and then press the SHUTTER dial in the direction of the arrow.
 - The FILE MANAGE screen appears in the viewfinder.
3. Choose the file to save in (A or B).
 - ① Turn the SHUTTER dial to select the STORE FILE item, and then press the SHUTTER dial in the direction of the arrow.
 - ② Turn the SHUTTER dial to select the file to save in (A or B), and then press the SHUTTER dial in the direction of the arrow.
4. Save the menu settings.

Turn the SHUTTER dial to align the cursor with the STORE item, and then press the SHUTTER dial in the direction of the arrow.

 - The "STORE OK?" message appears in the lower section of the centre of the screen.

When the SHUTTER dial is pressed in the direction of the arrow once more, the menu settings are stored in the selected STORE FILE.
5. Close the FILE MANAGE screen

Turn the SHUTTER dial to align the cursor with PAGE BACK, and then press the SHUTTER dial in the direction of the arrow.

 - The CAMERA MENU screen returns in the viewfinder.

Memo:

- When changing the menu settings in SCENE FILE A and saving in STORE FILE B: SCENE FILE B: The contents become the menu contents of the changed settings. SCENE FILE A: The contents become the menu contents valid before the settings were changed.
- When changing the menu settings in SCENE FILE OFF and saving in STORE FILE B: SCENE FILE B: The contents become the menu contents of the changed settings. SCENE FILE OFF: The contents become the menu contents of the changed settings.

- Resetting the menu settings to the initial settings is also done using the FILE MANAGE screen.

☞ See "Resetting the Camera Menu Settings" on page 78.

76

12. SETUP MENU

12-10 SETUP Screen

Item	Function, Operation	Variation Range	Initial Setting
H PHASE	For adjusting the horizontal phase of the unit in relation to the signal (external sync signal) input through the SYNC IN connector on the left side of the unit. Delaying the horizontal phase of the unit in relation to the external sync signal Increase the number Speeding up the horizontal phase of the unit in relation to the external sync signal Decrease the number * Adjustment is not possible if the external sync signal is not input. Possible values are indicated by ***.	0 to 256	128
SC PHASE	For adjusting the sub-carrier (SC) of the unit in relation to the signal (external sync signal) input through the SYNC IN connector on the left side of the unit. Rotating the sub-carrier clockwise in relation to the external sync signal Increase the number Rotating the sub-carrier anticlockwise in relation to the external sync signal Decrease the number * Adjustment is not possible if the external sync signal is not input. Possible values are indicated by ***. The phase will change when the power is turned on/off. The SC phase must be adjusted each time the power is turned on.	0 to 256	128
CAM MIC +48V	To set whether or not 48V voltage should be applied to the MIC IN connector on the front section. ON 48V applied. OFF 48V not applied.	ON OFF	ON
PAGE BACK	The CAMERA MENU returns when the SHUTTER dial is pressed with the cursor at this position.	—	—

12. SETUP MENU

12-11 Resetting of Camera Menu Setting Values

Using the FILE MANAGE screen, the CAMERA MENU settings can be reset to the initial setting values. On the FILE MANAGE screen, select the file of the CAMERA MENU to be reset, and then perform the resetting operation.

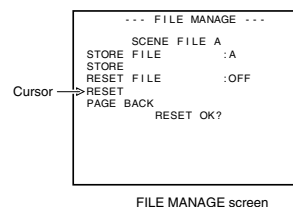
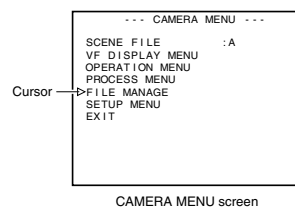
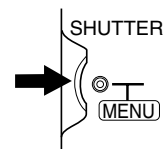
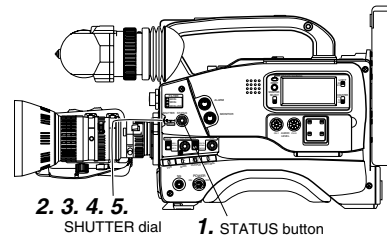

Reset Operation

- Press the STATUS button for about 1 second to display the CAMERA MENU screen.
- Turn the SHUTTER dial to align the cursor with the FILE MANAGE item, and then press the SHUTTER dial in the direction of the arrow.
 - The FILE MANAGE screen appears in the viewfinder.
- Choose the file of the CAMERA MENU to be reset (A, B, OFF or ALL)
 - If ALL is selected, all the CAMERA MENU files will be reset.
 - ① Turn the SHUTTER dial to align the cursor with the RESET FILE item, and then press the SHUTTER dial in the direction of the arrow.
 - ② Turn the SHUTTER dial to select the file to be reset, and then press the SHUTTER dial in the direction of the arrow.
- Reset the camera menu settings.
 - Turn the SHUTTER dial to align the cursor with the RESET item, and then press the SHUTTER dial in the direction of the arrow.
 - The "RESET OK?" message appears in the lower section of the centre of the screen.
 - When the SHUTTER dial is pressed in the direction of the arrow once more, the CAMERA MENU settings of the selected file are reset to the initial settings.
- Close the FILE MANAGE screen
 - Turn the SHUTTER dial to align the cursor with PAGE BACK, and then press the SHUTTER dial in the direction of the arrow.
 - The CAMERA MENU screen returns in the viewfinder.

13. FEATURES OF THE CAMERA SECTION

13-1 Full-Time Auto White Balance (FAW)

--- OPERATION ---	
SCENE FILE A	
SHUTTER	:STEP
▷ FAW	:NONE
GAIN L	:0dB
GAIN M	:9dB
GAIN H	:18dB
SMOOTH TRANS	:OFF
PAGE BACK	

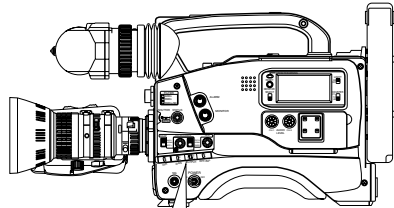

The FAW function adjusts the white balance value automatically as the lighting condition changes.

This mode is convenient when you have no time to adjust the white balance or when the camera is moved frequently in and out of places under different lighting conditions.

Setting procedure

The FAW function can be activated with item "FAW" on the OPERATION Menu.

This item allows allocation of the FAW function to the A, B or PRST position of the WHT.BAL selector switch.

☞ See "OPERATION Screen" on page 73.

CAUTION:

The FAW (Full-time Auto White balance) function cannot provide optimum white balance with a subject outside the FAW adjustment range, for example when it contains only a single color or not enough white color.

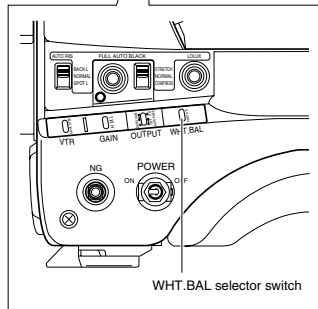

WHT.BAL selector switch

13. FEATURES OF THE CAMERA SECTION

13-2 IRIS (Brightness) Adjustment

ADJUSTMENT OF LENS IRIS

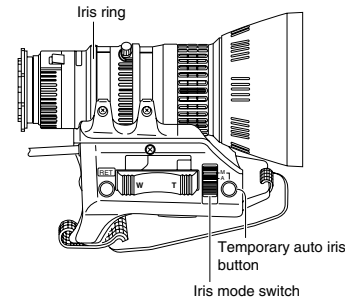

The lens iris can be adjusted using any of the following three methods.

• Automatic adjustment

Set the iris mode switch to "A" (Auto).

The iris is adjusted automatically according to the brightness of the object.

• Manual adjustment

Set the iris mode switch to "M" (Manual).

The iris can be adjusted manually by rotating the iris ring.

• Temporary auto iris adjustment

During manual iris adjustment, the auto iris adjustment mode is activated only while this button is held depressed.

■ Changing the auto iris adjustment setup

Under special lighting conditions such as backlight, it is often appropriate to change the value set by the auto iris adjustment.

This can be done by the following methods.

- Setting the AUTO IRIS LEVEL switch of the camera

☞ See "SWITCH FUNCTIONS" on page 83.

ZEBRA PATTERN DISPLAY DURING MANUAL ADJUSTMENT

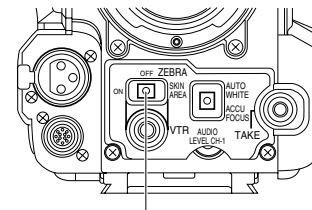

ZEBRA switch

By setting the ZEBRA switch to ON, oblique stripes (zebra pattern) can be displayed in the sections with a luminance level of 70% to 80% or sections with levels over 100% in the viewfinder.

The zebra pattern can be used as a reference for manual iris adjustment.

When adjusting the iris manually, adjust it so that the zebra patterns are displayed in the section that you want to stress in the subject.

- The initial setting is 70 to 80%. However, using the "ZEBRA" setting on the VF DISPLAY MENU, zebra patterns can be displayed in the sections with a luminance level of 85 to 95%, over 95% and over 100%.

☞ See "VF DISPLAY MENU Screen" on page 72.

13. FEATURES OF THE CAMERA SECTION

13-3 Shooting the Screen Image on a Computer Monitor

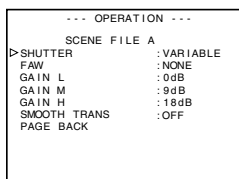
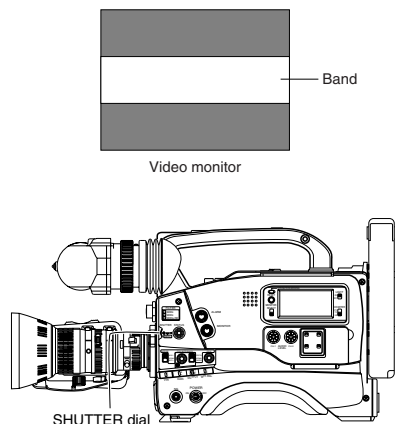

OPERATION MENU screen

■ Outline

The following operation allows the alignment of the shutter speed of the camera with the variable scanning rate of a computer monitor or display.

When a computer monitor screen or display is shot with the camera, a bright horizontal line indicating excessive exposure is displayed in cases when the scanning rate of the monitor is faster than the shutter speed of the camera. A dark horizontal line indicating insufficient exposure is displayed in cases when the monitor's scanning rate is slower than the camera's shutter speed.

The scanning frequency of a monitor varies due to various reasons during the computer operation. Adjust the scanning rate to obtain a stable image while observing the image in the viewfinder.

■ Variable Scan [V.SCAN]

• Basic operation

Set the SHUTTER item on the OPERATION MENU screen to VARIABLE. Then move the SHUTTER knob upwards or downwards to change the shutter speed. (The speed is displayed on the viewfinder screen.)

• Compatible frequencies

The variable scan function is compatible with scanning frequencies in the following range.
 60.1 to 2084.6 Hz (U-ver.)
 50.1 to 2067.8 Hz (E-ver.)

CAUTION:

This function is not compatible with slow-speed computer monitors with a vertical scanning speed of 60 Hz (U-ver.) / 50 Hz (E-ver.).

13. FEATURES OF THE CAMERA SECTION

13-4 Gain (Sensitivity) Adjustment

The gain should be switched when the brightness is insufficient due to poor lighting conditions.

GAIN SWITCHING

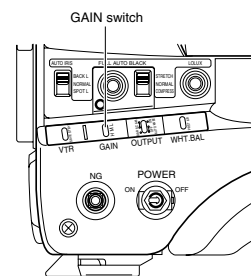

CAUTION:

When gain is set to "ALC", gain is boosted automatically as the illumination becomes darker. However, noise will increase a little because the screen becomes brighter as the ALC (Auto Level Control) function boosts the gain more than in the case of manual adjustment.

This switch allows the gain to be boosted when the illumination of the subject is insufficient.

Switch Position	Factory-Set Gain
L	0dB
M	9dB
H	18dB

When the GAIN switch is switched, the newly set gain is displayed for about 2 seconds on the Status 0 or Status 1 screen in the viewfinder.

Set it to L (0 dB) in normal use.

■ The gain set for each of the switch positions can be changed with "GAIN" on the OPERATION MENU screen.

■ It is also possible to use the ALC function that varies the gain automatically.

☞ See page 73 for details.

■ To make the gain transition smoother, set "SMOOTH TRANS" on the OPERATION MENU to "ON".

☞ See page 73.

However, note that the SMOOTH TRANS function is not available if gain is set to ALC.

GAIN BOOST UNDER LOLUX CONDITION

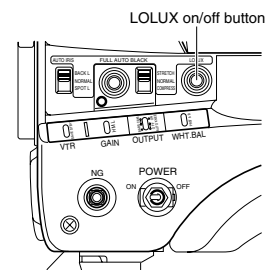

The LOLUX button is used when the illumination is still insufficient after compensating with the GAIN switch.

Press the button to enter the LOLUX mode in which the gain is boosted by about 33 dB.

"LOLUX ON" is displayed for about 2 seconds on the Status 0 or Status 1 mode screen in the viewfinder.

Pressing the button again cancels the LOLUX mode.

"LOLUX OFF" is displayed for about 2 seconds.

■ When the LOLUX function is in use, the image definition on the screen will degrade to increase residual images, but this is not a malfunction.

[Relationship between gain, iris and shutter]

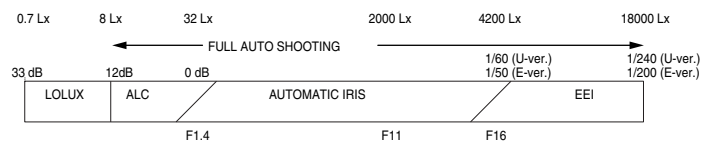

13. FEATURES OF THE CAMERA SECTION

13-5 Switch Setup According to Illumination and Subject

Various switch settings are performed to accommodate the conditions of the illumination and the subject when shooting.

SWITCH FUNCTIONS

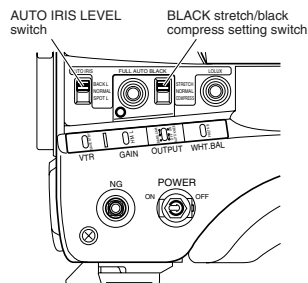

① AUTO IRIS LEVEL switch

This switch allows the reference value for the auto iris adjustment to be changed according to the lighting condition.

- BACK. L** : When the subject is in backlit conditions.
Sets the Auto Iris reference value to a value that is about 1 step wider than the standard setting.
- NORMAL**: Normal lighting condition.
- SPOT. L** : When the subject is under a spotlight.
Sets the Auto Iris reference value to a value that is about 1 step narrower than the standard setting.

② BLACK stretch/black compress switch

This switch makes the image easier to see by varying the black gain.

- BLACK STRETCH** : Boosts the gain of black areas to improve the reproducibility of black.
- NORMAL** : Normal black gain.
- BLACK COMPRESS** : Attenuates the gain of black areas to make the image sharper.

FULL AUTO SHOOTING (FAS) FUNCTION

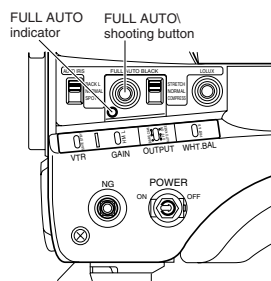

The FAS function provides a wide range of compatibility with shooting conditions that varies as you move between indoors and outdoors or between bright and dark locations. It eliminates the need to change the switch and filter positions every time you move.

The FAS function provides an integrated control of the ALC (Automatic Level Control), Auto iris and FAW (Full-time Auto White balance) functions.

Operation

- Simply press the FULL AUTO button to enter the FAS mode, in which the FULL AUTO indicator lights and "FAS" is displayed to the right in the viewfinder.
- Pressing the FULL AUTO button again cancels the FAS mode and turns the FULL AUTO indicator off.

Automatic Setting Contents

- If you have been displaying the color bars, the screen is switched automatically to the camera image.
- The auto iris adjustment mode is entered even if the iris mode switch of the lens is set to manual.
- The GAIN switch and WHT.BAL switch settings are defeated in the FAS mode.
- The LOLUX button setting is active even in the FAS mode. However, the ALC and EEI are defeated in the LOLUX mode, in which only the auto iris adjustment and FAW are used.
- All of the previous setting contents are recalled when the FAS mode is cancelled.
- The SMOOTH TRANS function is defeated during switch to the FAS function.

CAUTION:

- When the power is turned on while the camera is in the FAS mode, it takes about 10 seconds before the automatic adjustment of FAS is completed.
- In the FAS mode, the audio recording level is not set automatically to the AUTO mode.
To select the AUTO mode, set the AUTO/MANUAL switch of the VCR section to AUTO.

13. FEATURES OF THE CAMERA SECTION

13-6 How to Use Skin Detail

The contour emphasis in the skin color areas of the video signal can be controlled and made to appear gentle and smooth.

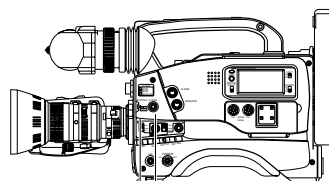

2 ~ 8. 1. STATUS button
SHUTTER dial

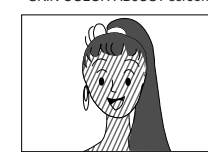
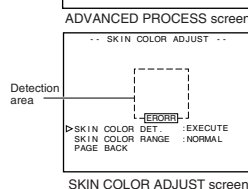
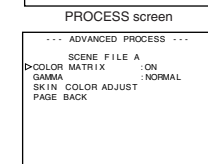
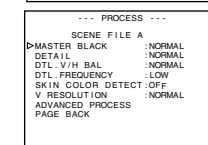
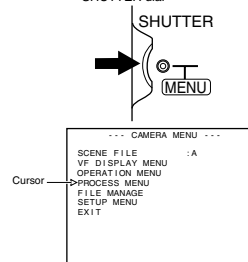

SKIN COLOR ADJUST screen

Setting the Color and Range of the Skin Detail Function

- Press the STATUS button for about 1 second to display the CAMERA MENU screen.
- Turn the SHUTTER dial downward to align the cursor (->) with the PROCESS item. Then press the SHUTTER dial in the direction of the arrow to display the PROCESS screen.
- Turn the SHUTTER dial downward to align the cursor (->) with the ADVANCED PROCESS item. Then press the SHUTTER dial in the direction of the arrow to display the ADVANCED PROCESS screen.
- Turn the SHUTTER dial downward to align the cursor (->) with the SKIN COLOR ADJUST item. Then press the SHUTTER dial in the direction of the arrow to display the SKIN COLOR ADJUST screen.
 - The frame shown on the screen indicates the detection area of the skin detail function.
- When the cursor (->) is aligned with the SKIN COLOR DET. item, the SHUTTER dial is pressed in the direction of the arrow and EXECUTE selected, the skin color detection mode is activated.
- Shoot so that the area with the color that you want to detect is brought within the detection area frame. To decide on the color for the detection, press the SHUTTER dial to set SKIN COLOR DET. to STOP.
 - The areas recognized by the skin detail function appear with superimposed zebra patterns.
 - If the color is not recognized as a color that the skin detail function works with, "ERROR" is displayed on the screen.
- If you want to change the color range recognized by the skin detail function, perform the following operations. Set the SKIN COLOR DET. item to EXECUTE.
 - Turn the SHUTTER dial to align the cursor (->) with SKIN COLOR RANGE, and then press the SHUTTER dial in the direction of the arrow.
 - The area with the setting value starts blinking, and the value can now be changed.
 - Turn the SHUTTER dial up or down to widen or narrow the color range.
 - Adjust the range while observing the zebra patterns.
 - To decide the color range, press the SHUTTER dial in the direction of the arrow.
 - The setting value stops blinking but remains lit.
- To stop the SKIN COLOR ADJUST operation, align the cursor (->) with BACK PAGE and press the SHUTTER dial in the direction of the arrow.

13. FEATURES OF THE CAMERA SECTION

13-6 How to Use Skin Detail (Cont'd)

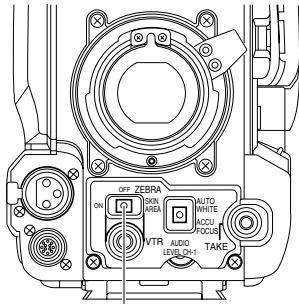

ZEBRA switch

■ Confirming the color tone area adjusted with the Skin Detail function

When the ZEBRA switch on the front section is pressed to the "SKIN AREA" side, the color tone areas adjusted with Skin Detail are displayed in the viewfinder.

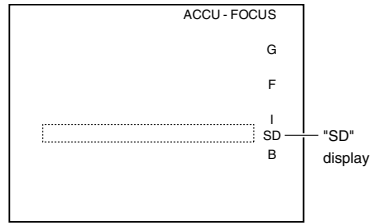

STATUS 0

■ Using the Skin Detail Function

To use the skin detail function set on the SKIN COLOR ADJUST screen, set the SKIN DTL DETECT item on the PROCESS menu to "ON".

While the Skin Detail function operates, the "SD" indicator is displayed on the Status 0 and Status 1 screen in the viewfinder.

14. OTHERS

14-1 Troubleshooting

Warnings concerning problems with the unit are provide in the form of indicators, display indications and monitor tones. The warnings are of the following two types.

- Alarm indications : These indications are given to provide warning on the status of the unit, for example when the tape or battery pack should be replaced.
- Error code display : In case an error occurs during operation, the unit self-diagnoses the cause and shows the diagnostics results on the counter display. When this happens, the unit stops operation automatically or ejects the videocassette.

ALARM INDICATIONS

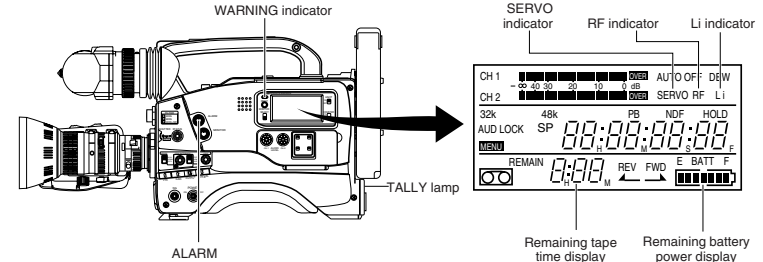

When an alarm is indicated, the unit operates in the following ways.

Alarm Indicator on VCR Display	Symptom	VCR Operation and Remedy
DEW	Indicates dew formation (condensation).	Operation : The VTR rejects operation. Remedy : Leave the power on, and wait until the indication disappears.
SERVO (Counter display) "Sync inh"	Lights in the case of troubles with the drum servo during recording. Lights when the input sync signal is disturbed or the unit is subjected to physical shock. (Displayed only in record mode)	Operation : During recording the mode becomes the stop mode. During playback, playback of the disturbed video image continues. Remedy : • Also check the input sync signal. • Signal is disturbed when the unit is subject to a violent shock. In other cases, please consult the person in charge of professional video equipment at your nearest JVC-authorized service agent.
RF (Counter display) "HEAD CLoG"	Lights in case of video head clogging. (Head clogging is detected and indicated during playback and recording check using the RET button on the lens section.)	Operation : Continues. Remedy : Clean the head with the special head cleaning tape. (See page 7 and the separate sheet "Precautions for Use of Head Cleaning Tape".)
(Counter display) Pc TAPE	Improper cassette type	Operation : Operation stops. Remedy : Use recordable MiniDV cassette for recording video and audio.
Li	Lights when the lithium battery for backup of time code generator and date/time data is exhausted.	Operation : Continues. Remedy : Replace with a new lithium battery. See page 34.
Remaining tape time 	* About 2 minutes before tape end. (The TALLY lamp and alarm sound are activated only in the record mode.)	Operation : Continues.
	* When the tape has ended completely.	Operation : Stops.
Remaining battery power 	When the remaining battery capacity is low.	Operation : Continues. Remedy : Replace battery pack early.
	When the battery capacity drops to an insufficient level.	Operation : Stops automatically. The camera may generate abnormal signals. This is not a malfunction.

14. OTHERS

14-1 Troubleshooting (Cont'd)

Alarm Indications (Cont'd)

Depending on the alarm conditions, the warning indicators in the LCD display, the WARNING indicator, the TALLY lamp, alarm tones and the viewfinder appear as shown in the following table.

Alarm Indications				Viewfinder		
LCD Display	WARNING Indicator	TALLY Lamp	Alarm Tone	WARNING Lamp		On Screen Display
				REC Lamp	BATT. Lamp	
"DEW" indicator					—	VTR WARNING (DEW)
"SERVO" indicator "SYnc inh" indicator					—	VTR WARNING (SERVO)
"RF" indicator "HEAd CLoG" indicator					—	VTR WARNING (HEAD)
"L" indicator	—	—	—	—	—	—
Remaining tape time					—	TAPE NEAR END
		(In record mode only)				About 2 min. before tape end.
					—	TAPE END
Remaining battery power						LOW BATTERY
		(Except for play/search mode)				
						LOW BATTERY

The WARNING indicator normally lights green or orange to indicate that operation is possible.

The color changes to red to indicate an alarm and appears as described above.

The alarm tone output is superimposed on the audio signal output from the monitoring loudspeaker or EARPHONE jack.

The volume of the alarm tone can be adjusted with the ALARM volume control.

Display symbols

● : Steady lighting. ○ : Blinking once per second. ⊗ : Blinking 4 times per second.
 : Continuous sound. : Sound interrupted once per second. : Sound interrupted 4 times per second.

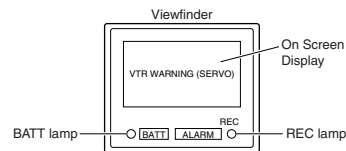

14. OTHERS

14-1 Troubleshooting (Cont'd)

WARNINGS IN VIEWFINDER

Viewfinder Warning Lamps

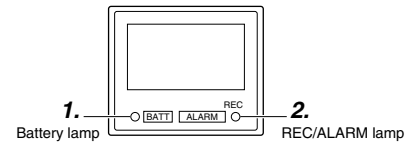

1. BATTERY lamp

This red lamp lights under the following circumstance.
Lights red : • When the battery voltage becomes too low for the camera to operate.

2. REC/ALARM lamp

This lamp lights or blinks green under the following conditions.
Lights Green : • While recording
Blinks Green : • During the interval where the unit switches from record-pause to record mode.
 • Immediately before the tape runs out or has run out.
 • If the unit malfunctions.

■ Character display warnings:

LOW BATTERY : This blinks when the battery level becomes too low.
TAPE NEAR END : Less than 3 minutes tape remaining.
TAPE END : The tape has run out.

■ Function Failures

When an abnormality occurs in the unit or an improper operation is performed, one of the following warning messages will appear in the viewfinder.

- **VTR WARNING (HEAD):**
Lights in case of video head clogging.
(Head clogging is detected and indicated during playback and recording check using the RET button on the lens section.)
- **VTR WARNING (SERVO):**
Lights in the case of drum servo trouble during recording.
- **VTR WARNING (DEW):**
Lights when condensation occurs in the unit.
- **VTR WARNING (STOP):**
Lights in case the unit stops operating.
- **VTR WARNING (HARD):**
Lights when abnormality occurs in the unit.
- **VTR WARNING (REW):**
Lights when abnormality occurs with tape rewind operation.
- **CLOSE CASSETTE COVER:**
Lights when the cassette cover has not been closed.
- **REC INHIBIT:**
Indicated when an unrecordable videocassette (the switch on the back of the cassette is set to SAVE) is loaded.
- **NO TAPE:**
Lights when the VTR trigger button is pressed with no videocassette loaded.

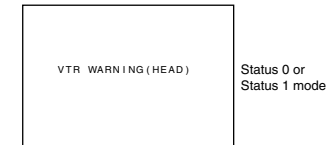

■ Warnings on the White Balance Function

- **AUTO WHITE A, B NG: OBJECT**
Improper object.
• Check whether the object being shot is white enough.
• Check that selected filter suits the illumination conditions.
- **AUTO WHITE A, B ERROR: LOW LIGHT**
Amount of incident light insufficient.
• Check to see if it is necessary to increase illumination or perform iris adjustment.
- **AUTO WHITE A, B ERROR: OVER LIGHT**
Amount of incident light excessive.
• Check to see if illumination and iris adjustment are appropriate.

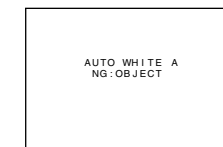

For servicing
See the service manual page 1-22 "1.16 WARNING CODES".

14. OTHERS

14-1 Troubleshooting (Cont'd)

In the case of troubles occurring during operation of the GY-DV500, it performs a self-test to identify the cause and displays the result in the form of an error code. The error code consists of the "main code" which indicates its contents and the "sub-code" which indicates the details. Depending on the status of the GY-DV500 at this time, indications may also appear on the LCD display, the WARNING indicator may activate and the alarm tone may be generated. In the viewfinder, the "VTR WARNING (DEW)" indication appears when condensation is detected, and the "VTR WARNING (STOP)", "VTR WARNING (HARD)" or "VTR WARNING (REW)" indication appears depending on the contents of the error code when some of the other error codes are displayed.

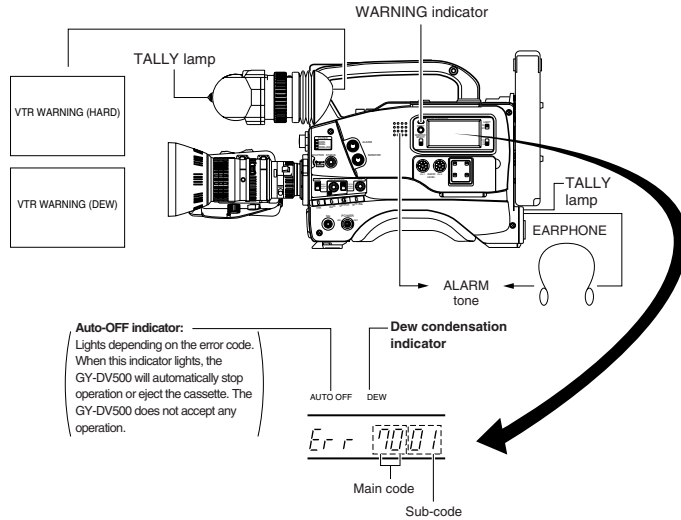

WARNING indicator	Alarm Tone	Display	GY-DV500 Operation
Red, blinking	Continuous	"Error code" "Error code" plus "AUTO OFF"	<ul style="list-style-type: none"> Automatically ejects the cassette. It can be inserted again. Automatically stops operation or ejects the cassette. (Auto OFF) * The GY-DV500 does not accept any operation.
Red, blinking	Intermittent	"DEW "	<ul style="list-style-type: none"> Dew condensation inside the unit. The GY-DV500 does not accept any operation until the DEW indicator disappears from the display.

* In the Auto OFF status, it is impossible to operate the GY-DV500. This condition can be cancelled by switching the POWER switch OFF and then switching it ON again. If the same problem occurs again after the power is turned ON, there may be something wrong with the GY-DV500. Please consult the person in charge of professional video equipment at your nearest JVC-authorized service agent.

The GY-DV500 is a microcomputer-controlled piece of equipment, which may malfunction due to external noise or interference. In this case, set the POWER switch to OFF, remove the lithium backup battery, and then set the POWER switch to ON again after a few minutes.

14. OTHERS

14-1 Troubleshooting (Cont'd)

TROUBLES WITH ERROR CODE OUTPUTS

Error Code	Error Details	GY-DV500 Operation	Remedy
3200	Tape loading impossible.	Operation stops. All operations are rejected.	Switch the power OFF and then switch it back ON. However, the tape may be damaged depending on the situation. Please consult the person in charge of professional video equipment at your nearest JVC-authorized service agent.
3300	Tape unloading impossible.	Operation stops. All operations are rejected.	
4000	Irregular cassette intake operation.	Operation stops. All operations are rejected.	
4100	Irregular eject operation.	Operation stops. All operations are rejected.	
4200	Cassette housing abnormality.	Operation stops. All operations are rejected.	Open the cassette cover by using the EJECT switch and then switch the power ON again.
5605	Tape is cut.	Operation stops. All operations are rejected.	
5606 to 5607	Tape is slack.	Operation stops. All operations are rejected.	Switch the power OFF and then switch it back ON. However, the tape may be damaged depending on the situation. Please consult the person in charge of professional video equipment at your nearest JVC-authorized service agent.
5702	Tape end sensor error.	Operation stops. All operations are rejected.	
5802	Tape beginning sensor error.	Operation stops. All operations are rejected.	
7001	Drum rotation stopped.	Operation stops. All operations are rejected.	Switch the power OFF and then switch it back ON. However, the tape may be damaged depending on the situation. Please consult the person in charge of professional video equipment at your nearest JVC-authorized service agent.
7101	Capstan rotation stopped.	Operation stops. All operations are rejected.	
7202 to 7203	Supply reel rotation error.	Operation stops. All operations are rejected.	Switch the power OFF and then switch it back ON. However, the tape may be damaged depending on the situation. Please consult the person in charge of professional video equipment at your nearest JVC-authorized service agent.
7302 to 7303	Take up reel rotation error.	Operation stops. All operations are rejected.	
7305	Irregular tape winding when unloading.	Operation stops. All operations are rejected.	

14. OTHERS

14-1 Troubleshooting (Cont'd)

TROUBLES WITHOUT ERROR CODE OUTPUTS

Symptoms	Remedy
Power cannot be switched ON.	<ul style="list-style-type: none"> Is power supply connected properly? Is battery pack recharged? When the lithium battery is depleted, it may not be possible to turn on the power. Was the power turned ON immediately after being turned OFF? Wait at least 5 seconds before turning the power ON again once it has been turned OFF.
Operation buttons on the GY-DV500 don't work.	<ul style="list-style-type: none"> Is the cassette cover open? The GY-DV500 remains inoperative as long as the cassette door is open.
Recording is not possible.	<ul style="list-style-type: none"> Is switch on cassette set to REC? If it is set to SAVE, set it to REC. When not connected via the DV connector, is the VCR Setup Menu item No. 126 INPUT SELECT set to "IEEE1394"? If so, set to "CAMERA".
Even if the image appears in the viewfinder, the signal is not output to the MONITOR OUT or YC OUT connectors. (U-ver. only)	<ul style="list-style-type: none"> When not connected via the DV connector, is the VCR Setup Menu item No. 126 INPUT SELECT set to "IEEE1394"? If so, set to "CAMERA".
Noise interferes with playback video.	<ul style="list-style-type: none"> Video head may be clogged with dirt. Clean head with the special head cleaning tape. (See page 7 and the separate sheet "Precautions for Use of Head Cleaning Tape".)
Sound and picture are disturbed during playback.	<ul style="list-style-type: none"> Is the sync signal input to the SYNC IN connector disturbed? If so, check and remedy the input sync signal.
Time code data is not shown as on-screen-display.	<ul style="list-style-type: none"> Time code data is not shown as on-screen-display during recording or playback. The data is shown only on the counter display.
Time code and user's bit data are not shown on the counter display.	<ul style="list-style-type: none"> Is the COUNTER switch set to "CTL"? If so, set the switch to "TC" or "UB".
Remaining battery power display is incorrect.	<ul style="list-style-type: none"> The VCR Setup Menu item No. 396 BATTERY TYPE may not be set correctly in accordance with the type of battery in use. If the menu item setting is incorrect, set it correctly using the VCR setup menu item BATTERY TYPE. Is the battery old?
Battery alarm is displayed and the GY-DV500 enters the non-operating mode even when a fully charged battery is used.	
Cassette cannot be ejected after the power is turned ON.	<ul style="list-style-type: none"> The capacity of the power supply may be insufficient. Check the power voltage.
Viewfinder image looks dark or unclear.	<ul style="list-style-type: none"> Adjust the viewfinder's contrast and bright controls. Is the filter turret set to 5600K+ND? Is the iris closed? Is the shutter speed too fast? Is the viewfinder cable correctly connected?
Noise appears when playing back a tape recorded on another unit.	<ul style="list-style-type: none"> When a tape recorded on another unit is played back or used for recording, this phenomenon may occur due to tracking errors.
The transient section between scenes recorded on other units and those recorded on this unit may appear disturbed.	
The front section's recording level control doesn't work.	<ul style="list-style-type: none"> Is the VCR Setup Menu item No. 246 FRONT VOLUME ENABLE set to "DISABLE"? If so, set to "ENABLE".
The front section's recording level control doesn't change the recording level of the sound input to CH2.	<ul style="list-style-type: none"> The front section's recording level control cannot be used to change the recording level of the sound input to CH2. Use the side section's CH2 recording level control for this purpose.
Recording operation stopped.	<ul style="list-style-type: none"> Is the SERVO indicator or "SYNC INH" displayed on the counter display? If so, check the input sync signal.

For servicing
See the service manual page 2-7 "2.4.3 Cleaning".

14. OTHERS

14-2 Hour Meter Display

The unit can display the accumulated running time of the head drum as hour meter data on the counter display. The hour meter can be displayed by selecting HM (HOUR METER) on the VCR Setup Menu. Use this as a guide for periodical maintenance.
See page 7.

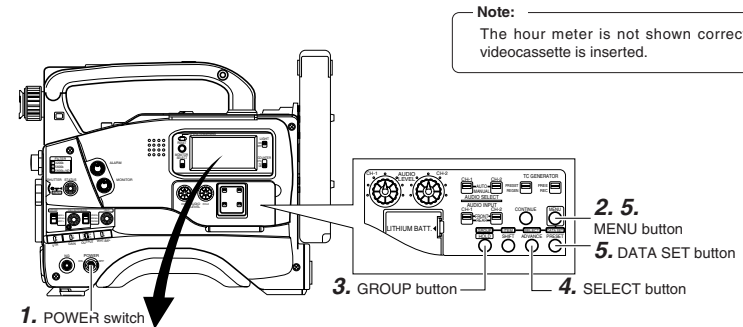

1. POWER switch

Counter display

24 00 02 00

Accumulated drum running time: 200 hrs.

Viewfinder

(HOUR METER)
DRUM HOUR METER
000200H

Note:

The hour meter is not shown correctly when no videocassette is inserted.

1. Set the POWER switch to ON.

2. Press the MENU button to display the VCR Setup Menu. "MENU" lights in the display, and the VCR Setup Menu's group menu appears in the viewfinder and on the counter display.

3. Press the GROUP button and choose "HM: HOUR METER".
• "HM HOUR METER" is shown blinking in the viewfinder. The counter display shows "Hour".

4. Press the SELECT button.
The accumulated running time of the head drum is indicated in the viewfinder and on the counter display.

5. To return to the normal mode, press the DATA SET button.
• Pressing the MENU button returns you to the group menu.

14. OTHERS

14-3 Specifications

■ CAMERA SECTION

Image pickup devices: 1/2-inch interline CCD x 3
Color separation optical system:
 F1.4 3-color separation prism

Number of effective pixels:
 380,000 pixels ((H) 768 x (V) 494) : U-ver.
 440,000 pixels ((H) 752 x (V) 582) : E-ver.

Color system
 : NTSC (R-Y, B-Y encoder)
 PAL (R-Y, B-Y encoder)

Color bars
 : SMPTE color bar : U-Ver.
 EBU color bar : E-Ver.

Sync system
 : Internal sync (built-in SSG)
 External sync (VBS or BB)

Lens mount
 : Bayonet system
 (compatible with 1/2-inch lenses)

Optical filter
 : 3200 K, 5600 K, 5600 K + ND (1/64)

Sensitivity
 : F11, 2000 lx

Minimum illumination: 0.75 lx (F1.4, LOLUX mode)

Gain
 : -3, 0, 6, 9, 12, 18 dB, ALC, LOLUX,

Shutter speed
 : 1/100, 1/250, 1/500, 1/1000, 1/2000 : U-ver.
 1/120, 1/250, 1/500, 1/1000, 1/2000 : E-ver.

V.SCAN speed
 : 60.1 Hz to 2084.6 Hz : U-ver.
 50.1 Hz to 2067.8 Hz : E-ver.

Registration
 : 0.05% or less (excluding lens distortion)

Contour correction
 : Horizontal: dual-edged. Vertical: 2 H

■ VCR SECTION

Format
 : Mini DV (SP mode only)

Tape speed
 : 18.812 mm/s : U-ver.
 18.831 mm/s : E-ver.

Record/Play time
 : 60 minutes
 (With M-DV60ME cassette)

F.F/Rewind time
 : Approx. 3 minutes 30 seconds
 (With M-DV60ME cassette)

[VIDEO]

Recording format
 : 8-bit, 13.5 MHz, 4:1:1 component recording : U-ver.
 8-bit, 13.5 MHz, 4:2:0 component recording : E-ver.

[AUDIO]

Recording format
 : 16-bit, 48 kHz, 2-channel PCM audio/12-bit, 32 kHz 2-channel PCM audio

Frequency response
 : 20 Hz to 20 kHz (48 kHz mode)

Wow & flutter
 : Below measurable limit

[Time Code System]

Time code signal
 : Compliance with SMPTE standard : U-ver.
 Compliance with EBU standard : E-ver.

■ INPUT/OUTPUT SIGNALS

Video signal output
 : 1 V (p-p), 75 ohms (BNC) unbalanced composite output.

YC output
 : Y 1 V (p-p) 75 ohms unbalance
 C 0.286 V (p-p) for U-ver. or 0.3 V (p-p) for E-ver. 75 ohms unbalance (4-pin)

Lens
 : 12-pin connector

Audio input
 : Microphone -60dBs, 3 kohm balanced (XLR-3)
 Line +4dBs, 10 kohm balanced (XLR-3)

Audio output
 : -6 dBs, low impedance, unbalanced

Earphone output
 : -60 dBs to -17 dBs, at 8-ohm load (Monaural mini jack)

DC input
 : 12V DC (11 to 15 V DC) (XLR-4)

Auxiliary power output
 : 12V DC, max. 0.1A (11 to 15 V DC) (4-pin)

DV connector
 : 4-pin

RS-232C
 : Mini DIN 6-pin

■ GENERAL

Power consumption
 : 18W with VF-P115B (when recording)

Mass
 : Approx. 5.0 kg (with lens, viewfinder, battery, videocassette). Approximately 2.9 kg (main unit only)

Operating temperatures
 : 0 °C to 40 °C (32°F to 104°F)

Operating humidity
 : 30 % RH to 80 % RH

Storage temperatures
 : -20 °C to 60 °C (-4°F to 140°F)

■ ACCESSORIES

Microphone
 : x 1

Tripod base
 : x 1

Lithium battery
 : x 1 (CR2032)

Head cleaning tape
 : x 1

Instruction Manual
 : x 1

Precautions for Use of Head Cleaning Tape
 : x 1

Design and specifications are subject to change without notice.

14. OTHERS

14-3 Specifications (Cont'd)

OPTIONAL ACCESSORIES

Viewfinder
 : VF-P115B, VF-P116

Power zoom lens
 : S14 x 7.3B12, S16 x 6.7B12, S19 x 6.5B12 (FUJINON)
 YH14 x 7.3K12, YH18 x 6.7K12 (CANON)

AC power adapter
 : AA-P250

Microphone
 : MV-P615

Microphone holder
 : KA-A50

EXTERNAL DIMENSIONS (unit: mm)

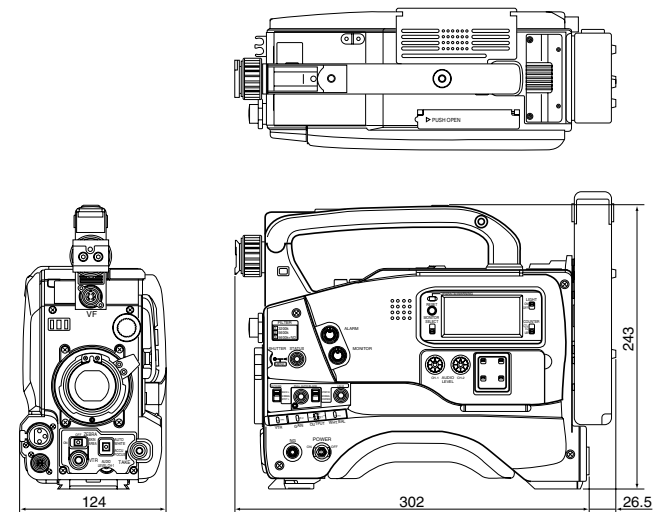

* Design and specifications are subject to change without notice.